



NRL/MR/6120--97-7957

Control of Lead in Drinking Water

ROBERT F. BRADY, JR.
JAMES D. ADKINS

*Materials Chemistry Branch
Chemistry Division*

July 11, 1997



19970729 024

DTIC QUALITY INSPECTED 1

Approved for public release; distribution unlimited.

REPORT DOCUMENTATION PAGE

Form Approved
OMB No. 0704-0188

Public reporting burden for this collection of information is estimated to average 1 hour per response, including the time for reviewing instructions, searching existing data sources, gathering and maintaining the data needed, and completing and reviewing the collection of information. Send comments regarding this burden estimate or any other aspect of this collection of information, including suggestions for reducing this burden, to Washington Headquarters Services, Directorate for Information Operations and Reports, 1215 Jefferson Davis Highway, Suite 1204, Arlington, VA 22202-4302, and to the Office of Management and Budget, Paperwork Reduction Project (0704-0188), Washington, DC 20503.

1. AGENCY USE ONLY (<i>Leave Blank</i>)	2. REPORT DATE July 11, 1997	3. REPORT TYPE AND DATES COVERED July 1996-April 1997	
4. TITLE AND SUBTITLE Control of Lead in Drinking Water		5. FUNDING NUMBERS	
6. AUTHOR(S) Robert F. Brady, Jr. and James D. Adkins		8. PERFORMING ORGANIZATION REPORT NUMBER NRL/MR/6120--97-7957	
7. PERFORMING ORGANIZATION NAME(S) AND ADDRESS(ES) Naval Research Laboratory Washington, DC 20375-5320		10. SPONSORING/MONITORING AGENCY REPORT NUMBER	
9. SPONSORING/MONITORING AGENCY NAME(S) AND ADDRESS(ES)		11. SUPPLEMENTARY NOTES Environmental Security Technology Certification Prog. ODVSD (ES) 3000 Defense Pentagon Washington, DC 20301-3000	
12a. DISTRIBUTION/AVAILABILITY STATEMENT Approved for public release; distribution unlimited.		12b. DISTRIBUTION CODE	
13. ABSTRACT (<i>Maximum 200 words</i>) This report describes the installation of an NRL-developed epoxy lining in the drinking water distribution system in three buildings. Water was sampled before and after installation of the lining; the sampling data was interpreted after several confounding factors were identified and allowed for. Improper installation of the lining in one of the buildings led to its premature failure, and this was documented and analyzed. The lining is shown to be effective in preventing leaching of lead into drinking water. This technology is recommended as a routine method for excluding lead from drinking water distribution systems in buildings, and guidance for use in establishing contracts to install the lining is provided.			
14. SUBJECT TERMS Epoxy lining Drinking water		Lead Heavy metal	15. NUMBER OF PAGES 113
17. SECURITY CLASSIFICATION OF REPORT UNCLASSIFIED		18. SECURITY CLASSIFICATION OF THIS PAGE UNCLASSIFIED	16. PRICE CODE
19. SECURITY CLASSIFICATION OF ABSTRACT UNCLASSIFIED		20. LIMITATION OF ABSTRACT UL	

Table of Contents

1. Introduction	1
1.1 Background Information	1
1.2 Official DoD Required Statement	1
1.3 Objectives of the Demonstration	2
1.4 Regulatory Issues	2
1.5 Previous Testing of the Technology	3
2. Technology Description	3
2.1 Description	3
2.1.1 Equipment	4
2.1.2 Materials	4
2.1.3 Evaluation of Pipe Prior to Beginning Work	5
2.1.4 Initial Preparation of the Site	6
2.1.5 Cleaning	6
2.1.6 Lining	7
2.1.7 Restoration of the Piping System	8
2.2 Strengths, Advantages and Weaknesses	9
2.3 Factors Influencing Cost and Performance	10
3. Site/Facility Description	10
3.1 Background	10
3.2 Site/Facility Characteristics	11
4. Demonstration Approach	15
4.1 Performance Objectives	15
4.1.1 Minimal Operational Disruption	15
4.1.2 Minimal Process Wastes	15
4.1.3 Reliability and Reproducibility	15
4.2 Physical Setup and Operation	15
4.2.1 Equipment	17
4.2.2 Materials	17
4.2.3 Evaluation of Pipe	21
4.2.4 Initial Preparation of the Site	22
4.2.5 Cleaning	24
4.2.6 Lining	24
4.2.7 Restoration of the Piping System	25
4.2.8 Sampling and Inspection System	25
4.3 Sampling Procedures	25
4.4 Analytical Procedures	26

Table of Contents (continued)

5. Performance Assessment	26
5.1 Obtaining Samples of Tap Water for Analysis of Lead	26
5.1.1 Faucets out of Service	28
5.1.2 Interference Between Taps	28
5.1.3 Fixtures	28
5.1.4 Continuing Use	28
5.2 Performance Data	28
5.1.1 Building A171	28
5.1.2 Building A2-87	28
5.1.3 Building A93	28
5.3 Followup Assessments After Lining	29
5.3.1 Calibration of the Metalyzer	29
5.3.2 Building A171	29
5.3.3 Building A2-87	33
5.3.4 Building A93	34
5.4 Conclusions	34
5.5 Technology Comparison	35
6. Cost Assessment	35
6.1 Cost Performance	35
6.2 Cost Comparisons to Conventional and Other Technologies	37
6.2.1 Factors Related to Any Method of Rehabilitating Pipe	37
6.2.2 Factors Related to the Demonstrated Technology	37
6.2.3 Costs of Replacing Pipe in Building A93, the Bachelors Officers Quarters	38
7. Regulatory Issues	38
7.1 Approach to Regulatory Compliance and Acceptance	38
8. Technology Implementation	39
8.1 DoD Need	39
8.2 Transition	39
9. Lessons Learned	39
10. References	40

Table of Contents (continued)

Tables

Table 1. Aircraft Carriers with Epoxy Linings	3
Table 2. Baseline Lead Determinations, March and September, 1995	27
Table 3. Metal Determinations, August, 1996, after Lining	30
Table 4. Day 1 (February 27) Samples: Lead (Copper) Concentrations, ppb	32
Table 5. Day 2 (February 28) Samples: Lead (Copper) Concentrations, ppb	33
Table 6. Samples: Lead (Copper) Concentrations, ppb	34
Table 7. Cost Data Table	36

Appendices

Appendix A. Points of Contact	41
Appendix B. Data Archiving and Demonstration Plans	46
Appendix C. Contractor's Production Reports	47
Appendix D. Contracting Guidance	66
Appendix E. Materials Safety Data Sheets for the NRL Series 4 Lining	71
Appendix F. Analysis of the Failure of the Lining in Building A93	83



Control of Lead in Drinking Water

Naval Research Laboratory

1. Introduction

1.1 Background Information

Corrosion of water piping systems introduces impurities into drinking water. When these impurities are heavy metals such as lead, the quality of the water may fail to comply with the requirements of the Safe Drinking Water Act and other regulations. The usual remedies for this situation are to replace the piping or to bring in bottled drinking water; several Defence facilities have been taken out of service until the safety of their drinking water distribution systems could be assured.

A chemically-resistant nontoxic epoxy lining for water pipes (FIGURE 1, page 2) has been developed at the Naval Research Laboratory. This pipe lining has been tested and approved¹ for contact with domestic hot and cold drinking water by NSF International of Ann Arbor, Michigan, the sole firm authorized by the Environmental Protection Administration to test and approve materials for contact with drinking water.

This lining is applied to the interior of pipes by compressed air. The operation causes minimum disruption to tenants or their activities and may be used on systems with varying diameters of pipe. Piping may be lined without removal or disassembly and returned to service within 72 hours.

1.2 Official DoD Required Statement

This project responds to DoD Requirement 2.V.1.p, Assessment and Control of Lead in Drinking Water (1995).

Manuscript approved May 29, 1996

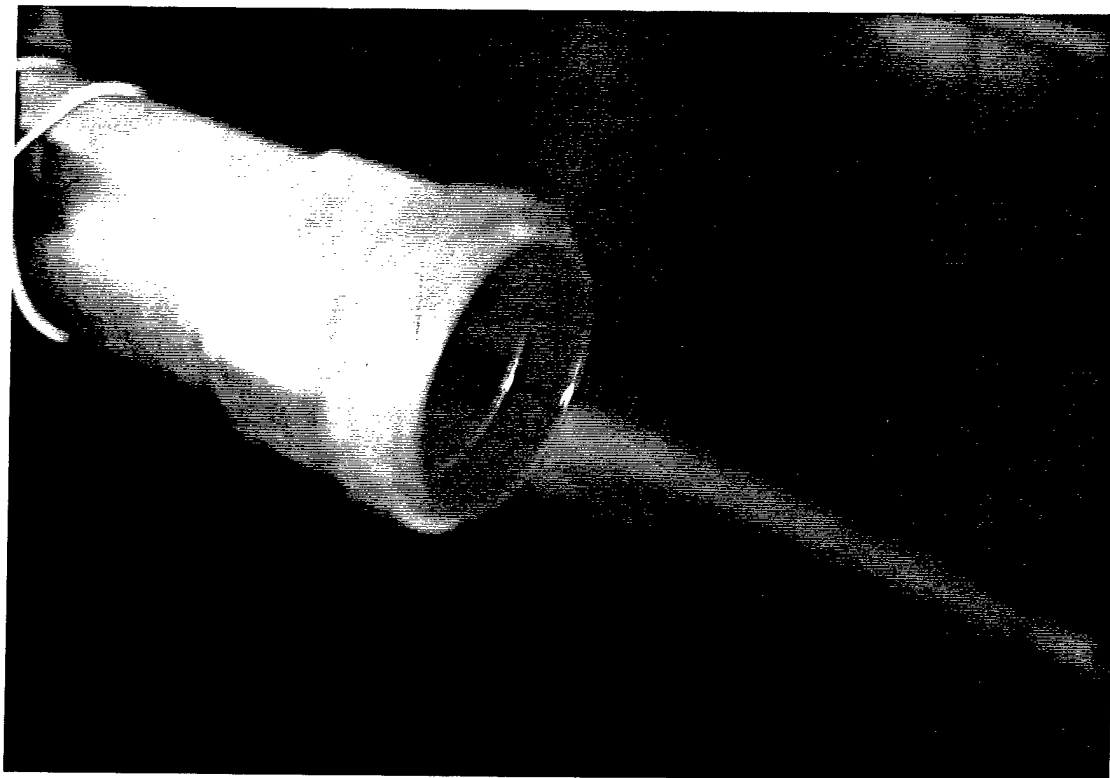

Figure
1

1.3 Objectives of the Demonstration

The purpose of this ESTCP Demonstration Program is to show that the NRL epoxy lining can be applied to the interior of drinking water systems in defense buildings and that this lining effectively prevents pipe corrosion and reduces levels of lead and other heavy metals in the water.

This technology is recommended for the renovation of existing structures where water quality testing has indicated the presence of lead at concentrations above the allowable legal level, 15 micrograms per liter ($\mu\text{g}/\text{L}$) (15 ppb). Lining the interior of potable water pipes places a barrier between any source of lead, usually the pipe itself or old solders, and the water. Lining is an economical alternative to abandoning the structure, replacement of contaminated piping, particularly in older buildings where access to existing pipes is restricted, asbestos removal would be a major undertaking, the use of bottled water is costly or unacceptable, or a combination of these factors exists.

1.4 Regulatory Issues

The level of lead and other heavy metals in water is regulated by the Safe Drinking Water Act.

1.5 Previous Testing of the Technology

Since 1987 the Naval Research Laboratory has been involved in the development and testing of coatings for the in-place lining of shipboard piping systems, particularly aircraft carrier collection, holding and transfer (CHT) systems which are subject to severe corrosion. At this time all aircraft carrier CHT systems but one (See Table 1) have been retrofitted with NRL's 2-component epoxy coatings and have exhibited long life and maintenance-free operation. Beginning with the USS JOHN C STENNIS (CVN 74) in November, 1995, all new carriers are now being delivered with the epoxy pipe lining installed in the CHT system.

Table 1. Aircraft Carriers with Epoxy Linings

CV 41 USS MIDWAY	CV 66 USS AMERICA
CV 43 USS CORAL SEA	CV 67 USS JOHN F KENNEDY
CV 59 USS FORRESTAL	CVN 68 USS NIMITZ
CV 60 USS SARATOGA	CVN 69 USS DWIGHT D EISENHOWER
CV 61 USS RANGER	CVN 70 USS CARL VINSON
CV 62 USS INDEPENDENCE	CVN 71 USS THEODORE ROOSEVELT
CV 63 USS KITTY HAWK	CVN 72 USS ABRAHAM LINCOLN
CV 64 USS CONSTELLATION	CVN 73 USS GEORGE WASHINGTON
CVN 65 USS ENTERPRISE	CVN 74 USS JOHN C STENNIS ¹

Note 1. In November 1995, the USS JOHN C STENNIS was delivered with an epoxy lining in her CHT system, becoming the first ship to be lined during construction.

2. Technology Description

2.1 Description

The demonstrated technology consists of isolating sections of pipe, drying the pipe with dry compressed air, grit blasting the interior to remove corrosion products and provide a clean rough surface, injecting a 100% nonvolatile paint into the pipe with compressed air to coat the surface, and finally passing a stream of warm dry air through the pipe while allowing the coating to dry and cure. The coating to be used must have certification from NSF International for use in potable water systems and the quality of the water from the coated pipe system must be tested and approved prior to returning the system to service.

Pipes are lined without removal or disassembly. Trailer-size air compressors are placed outside the building and air hoses lead inside where they are connected to the piping system. A hose on the end of the pipe leads outside to a dust collector. Hot dry air is blown through

the pipe, and abrasive grit is added to remove rust or other contaminants and give the inside of the pipe a rough surface. Paint is then blown through the pipe, where it hardens in about 20 minutes. The stream of hot air is maintained for about an hour to dry the paint thoroughly. After 16 hours water is flushed through the pipe and then allowed to stand undisturbed for 12 hours; this process is repeated. The water is then tested to make sure no undesired substances are present. The pipe is returned to service within 72 hours. The lining process is conducted as follows:

2.1.1 Equipment

A. Air supply equipment provides sufficient air volume and air stream velocity to effectively clean and line the pipe. This velocity is required to carry the blast grit through the pipe fast enough to clean the pipe and to provide an adequate anchor tooth for the epoxy lining.

B. In-line water and oil filters are located between the equipment and point of entry to the piping system. These filters are periodically inspected and serviced to ensure delivery of uncontaminated dry air. The maximum allowable size of airborne particles of oil or water is $0.75 \mu\text{m}$ (0.03 microns).

C. Moisture is removed from the compressed air by use of an air aftercooler or dryer to prevent condensation in the piping being worked.

D. A heater is used to raise the temperature of the compressed air and the pipe downstream from the aftercooler to provide further protection against moisture condensation in the piping. After reheating, the working air temperature is approximately $68 \text{ }^\circ\text{C}$ ($155 \text{ }^\circ\text{F}$) at an ambient air temperature of $27 \text{ }^\circ\text{C}$ ($80 \text{ }^\circ\text{F}$).

E. An air pressure regulator is used to regulate the pressure of the air entering the pipe to be cleaned and lined, usually in conjunction with a manifold system.

F. A device is used to inject the abrasive grit into the air stream at a measured rate.

G. A dust collector is installed at the discharge of the pipe which fully collects all spent grit, contaminated dust, and excess epoxy coating during the lining process.

2.1.2 Materials

A. Masking materials must be used to provide protection of the flange faces of the pipe being lined without causing corrosion or contamination.

B. Abrasive materials shall be pure garnet. Garnet is prescribed because it leaves very little dust residue in the pipe, for the epoxy paint will not adhere to the substrate when dust is present. Abrasive blasting particles of various grades may be used to clean the pipe and to provide an anchor tooth of $50\text{-}75 \mu\text{m}$ (2 to 3 mils) during final surface preparation of the

substrate. Abrasives must be clean and dry, contain less than 5 percent fines (smaller than 30 mesh by weight), and contain no feldspar, iron, aluminum, or other materials which might remain embedded in the surface or create galvanic interaction with the pipe. To prevent contamination of the substrate, previously used abrasive particles must not be used for surface preparation.

C. Only new grit which passes the following oil contamination test may be used.

- (1) Fill a clean 150 mL (5 ounce) bottle half full of screened abrasive particles.
- (2) Fill the remainder of the bottle with clean water.
- (3) Cap and shake the bottle.
- (4) Inspect water for oil sheen.
- (5) If any oil is observed, the abrasive particles shall not be used.

D. The epoxy coating used for pipe lining is an NRL Series 4 lining approved under ANSI/NSF Standard 61 for this purpose.² This coating has been developed by the Naval Research Laboratory specifically for use in drinking water pipes.

The coating consists of two components which must be mixed immediately before use. A Material Safety Data Sheet (MSDS) for each component is included in Appendix E of this report. The first component contains a liquid epoxy resin, red iron oxide, and a thickening agent. The second component contains a polyamide curing agent.

2.1.3 Evaluation of Pipe Prior to Beginning Work

A. Prior to blasting with grit, the contractor will ensure that the pipe to be lined is intact, has no holes, and has a minimum wall thickness of at least 50 percent of the original. In potable water pipe, the wall thickness shall be measured randomly on the pipe and within two feet downstream of the inside and outside of bends. The wall thickness of the pipe shall be measured at suitable intervals along the pipe, but at least every 50 feet. The wall thickness on vertical pipe shall be measured by taking four readings at 90° to each other. The contractor shall install flanged mechanical joints at all tees where one of the legs is not to be lined.

B. The recommended ultrasonic tester for pipe thickness is the Panametrics Model 26 DL Microprocessor-based Corrosion Gauge with built-in Data Logger, available from Panametrics, Inc., 221 Crescent Street, Waltham, Massachusetts 02254 (800-225-8330).

C. The contractor will identify dissimilar metals in the system that may become a potential cause of deterioration to the system.

D. The contractor will determine the presence of non-standard layouts or items in the system that could affect its performance.

E. The contractor will identify the presence and extent of external corrosion in the system.

F. The contractor will identify the presence and extent of asbestos insulation on or around the piping system to be worked on.

G. The contractor will identify any lead in the system from lead-based solder or lead pipe and fittings.

2.1.4 Initial Preparation of the Site

A. Take a sample of the water to establish the baseline concentration of lead or other heavy metals.

B. If asbestos is found in areas that have to be disturbed, remove and dispose of all asbestos in strict compliance with applicable regulations and guidelines only in these areas.

C. Remove and replace all valves, fixtures, appliances and piping sections whose thickness is less than 50% of original.

D. Fabricate and install make-up pieces where needed in place of the items removed.

E. Convert all joints to mechanical fittings to provide for reassembly after lining to permit restoration of the system without application of heat from welding.

F. Perform an initial air pressure test to check the integrity of the system. Repair or replace leaking components. Pressurize the system with air to 70 psi and ensure that this pressure is maintained for 5 minutes.

G. Secure a connection/transition piece to every water outlet point within the run segment.

H. Secure air hoses to every connection/transition piece in the run segment.

2.1.5 Cleaning

A. The piping is grounded to ensure that all static electricity is dissipated.

B. A HEPA (High Efficiency Particulate Absorbent) filter is installed at the run outlet(s) to remove any particles created during the cleaning step.

C. Hot, dry, oil free compressed air is forced through the run segment until the pipe is thoroughly dried.

D. The pipe section is cleaned by injecting garnet grit into the flowing compressed air stream. Grit blasting is continued in each pipe run until an anchor tooth pattern of 1-3 mils (25-75 μm) is established.

E. The Pipe section is purged with compressed air to clear dust and loose materials. Particulates are collected at the end of the pipe section and disposed of in accordance with all applicable regulations.

F. A pressure test is run on each segment to verify the integrity of the system after cleaning. The pipe must hold 70 psi pressure for 5 minutes.

G. Each section of pipe is visually inspected with a borescope for cleanliness and proper anchor tooth pattern. The prepared surface shall have a white-metal blast appearance, and an anchor-tooth (not peened) surface profile of 50-75 $\mu\mu$ (2 to 3 mils) which is validated (measured) at the pipe inlet and outlet with profile tape and a dial micrometer. The color of the clean surface may be slightly affected by the particular abrasive medium used. The surface, when viewed using a magnification of 10x, shall be free from oil, grease, dust, dirt, mill scale, corrosion products, oxides, paint, and other foreign material. Blasting shall not be so severe as to wear the pipe below 45 percent of the original pipe thickness. Prepared surfaces shall not be handled. Contact with any oil or grease (such as touching with a bare hand) will result in reduced bonding of the coating.

2.1.6 Lining

A. The pipe is dried again with hot, dry, oil-free compressed air and heated to a temperature high enough above the dew point to prevent condensation of moisture on the substrate. The temperature of the pipe shall be 5 °C (10 °F) above the dew point of the air used for coating; otherwise no epoxy lining shall be conducted. The air temperature must be between 50 and 120 °F.

B. The two components of the NSF-approved epoxy paint (see 2.1.2 D) are weighed out in the proper ratio, mixed thoroughly by mechanical means, and injected into the entry of the pipe segment in a quantity sufficient to coat the entire interior surface at twice the desired thickness. Because this paint cures very rapidly after mixing, this procedure is carried out with all deliberate speed.

C. The compressed air is then applied at the proper pressure and for the required duration to accomplish the interior coating of the piping segment. The emergence of paint at the end of the pipe segment is determined by observing it in a section of clear plastic pressure hose connected to the outlet line. After adequate drying, a second coat (and a third coat if necessary) can be applied in the same manner as the first coat if the inspection criteria listed in subparagraph G below are not satisfied.

D. At 75 °F (24 °C) ambient, time between successive coats shall not exceed 24 hours. Should the 24-hour limit be exceeded, an anchor tooth profile must be reestablished by a light blasting with garnet grit. An additional 12 hours between successive coats is allowed for every 18 °F (10 °C) drop in temperature.

E. After the last coat of epoxy lining has been applied, hot air is passed through the pipe system for 12-18 hours to complete the curing of the epoxy lining.

F. The process is repeated for each pipe run until the entire system has been coated.

G. The coated pipe is inspected visually using a borescope as far into the pipe as is practical at each end to ensure it is uniform and free of film defects. Test pipes installed within the system being coated or at the ends are inspected in the same way. After drying and curing, the epoxy pipe lining shall not contain bubbles, blisters, fisheyes, cracks, chips or loosely-adhering particles, oil or other surface contaminants, pinholes, voids, holidays, or pits exposing the underlying metal. Minor hanging paint spikes and paint pooling in the bottom of the pipe shall not be justification for relining the pipe.

(1) Knife-peel test. The coating shall not be separated from the base metal when subjected to a knife-peel test. This test consists of a single knife cut 40 mm (1.5 inches) long through the epoxy pipe lining to the substrate. If any part of the coating along the cut can be separated from the base metal using the knife, the bond shall be deemed unsatisfactory.

(2) Bond test. Adhesion of the lining to the pipe shall pass the crosshatch adhesion test (Method A of ASTM D 3359)³ with a 5A rating.

(3) Thickness. Each coat of lining must be between 150 and 225 μm (6-9 mils) thick. The total thickness of the complete epoxy coating shall be at least 375 μm (15 mils) at every point. On vertical pipe runs the thickness shall be no more than 400 μm (20 mils) at any point around the circumference of the pipe. Thickness measurements shall be performed using a calibrated film thickness gage (Nordson Film Gage Number 790010, Nordson Corp., Amherst, Ohio, or equivalent), or using a micrometer with readings taken before and after application of the epoxy lining.

2.1.7 Restoration of the Piping System

A. After the paint has dried sufficiently all valves and other make-up pieces are installed.

B. A pressure test is done with compressed air to test the integrity of the piping, valves and joints. The pipe must hold 70 psi pressure for 5 minutes. Repairs are made as necessary.

C. Fixtures and appliances are reconnected.

D. Potable water is introduced into the system at its normal operating pressure.

E. The entire system is flushed with a minimum of twenty-five volumes of potable water.

F. The entire system is then filled with potable water and allowed to stand without disturbance for twelve hours.

G. The entire system is again flushed with a minimum of twenty-five volumes of potable water and then allowed to stand without disturbance for twelve to eighteen hours prior to sampling.

H. Samples of water are taken from the tap and analyzed by either the reference or the field method. The system is returned to service only after testing shows acceptable water quality. If necessary small samples of water representing, for example, water within the tap fixture itself or water within the local supply lines, are taken to assess the amount of heavy metal contamination which arises from each part of the piping system.

2.2 Strengths, Advantages and Weaknesses

This technology rehabilitates deteriorated drinking water systems by installing a non-toxic lining which prevents corrosion and leaching of lead and other heavy metals into drinking water. The advantages of this method are:

A. Rapid compared with replacing pipe (work on a 40- by 60-foot residential structure, including initial evaluations and inspections after lining, usually requires less than 72 hours).

B. Suitable for use inside buildings and underground.

C. Suitable for bent pipes and pipes of different diameters.

D. Economical compared with the cost of replacing pipe.

E. Suitable for pipe diameters between 1/2" and 24".

F. Suitable for pipe runs up to 1000' long.

G. Minimally disruptive of tenants and their activities.

Disadvantages of this method of pipe rehabilitation are:

A. No welding or other hot work may be performed on the lined pipe, but soldering is acceptable.

B. The lining is hard and tough, but can be damaged or removed by deliberate and prolonged mechanical abuse.

C. Hot water in the pipes is limited to 160 °F. Because domestic hot water is usually regulated at 140 °F to minimize the danger of scalding, this does not present a problem under normal conditions.

D. If the pipe is cut, loose paint at the site must be removed before the system is closed.

2.3 Factors Influencing Cost and Performance

Factors which affect cost of this process include:

- A. Accessibility and complexity of the piping systems.
- B. Presence of asbestos.
- C. Amount of pipe replacement necessary due to corrosion or bad design.
- D. Number of unions, joints, and fixtures required, and.
- E. Degree of tenant disruption which requires limiting work schedules.

Factors affecting performance are:

- A. Quality of surface preparation.
- B. Thoroughness of removal of blasting dust before lining.
- C. Thoroughness of coating mixing prior to application.
- D. Uniformity of the applied lining.
- E. Complete curing of the lining after application.
- F. Complete flushing of the water system before return to service.

3. Site/Facility Description

3.1 Background

During March 1995 the demonstration participants met with the Public Works Department of the Naval District of Washington (NDW) at the Washington Navy Yard (WNY). The Washington Navy Yard and the adjoining Anacostia Naval Annex (ANA), located directly across the Anacostia River from the WNY, are suitable sites for this demonstration project because they contain a variety of buildings of different ages, method and material of construction, and present use. In addition, the site is easily accessible and does not have any security requirements which might impede access of the contractor or visiting government personnel.

At the meeting the participants reviewed the age, construction, and history of most of the buildings at the WNY and the ANA. A preliminary selection of nine buildings was made, and water samples were taken for analysis. As a result of the sampling and analysis of drinking water from nine buildings on the WNY and ANA, three buildings of disparate size, age, construction and use were chosen for lining. These are described in Section 3.2 below.

3.2 Site/Facility Characteristics

Two maps are included on pages 12 and 13. The first shows the Anacostia Naval Annex and the surrounding neighborhood; the second is a detailed map of the site, with the demonstration buildings marked.

Anacostia Naval Annex building 2-87 (FIGURE 2, page 14) is one structure formed by the union of two smaller buildings. ANA 2 is an old one-story house and ANA 87 is a newer one-story addition; together they now are used as a detention facility. The building measures about 30 by 60 feet. It contains a bath area with toilets, showers, and sinks at the north end of the building, a hot water heater and janitor's sink in the center, two restrooms with toilets and sinks at the north end, and two isolation cells with toilets and sinks also at the north end of the building. The water main is cast iron and rises from the ground into an administrative area in the middle of the east side of the building and goes through the ceiling to the hot water heater. From that point copper pipes distribute hot and cold water throughout the structure.

Anacostia Naval Annex building 93 (FIGURE 3, page 14) is a 2-story Bachelor Officers' Quarters with 30 sleeping rooms. The building measures about 50 by 150 feet and is laid out similar to a commercial motel. Rooms are on each side of a central corridor; each room has a shower, toilet and sink. The second floor contains sleeping rooms and a small kitchen in the center of the east side for use by the residents. The first floor contains a wet bar on the north end, hot water heaters and a janitor's closet in the center, and administrative offices and some sleeping rooms on the south end. The first floor is about six feet off the ground, and the water main is located in the crawl space under the first floor. The water main enters the building under the room where the hot water heaters are located; from that point copper pipe in the first floor ceiling distributes water throughout the building.

Anacostia Naval Annex building 171 (FIGURE 4, page 16) is the *Legends*, a one-story snack bar which serves light meals at lunch time. The building measures about 40 by 120 feet and was formerly the *Acey-Deucey* NCO Club. The building has a kitchen area with sinks in the center of the west side, and men's and women's restrooms are located at the north end and center of the building. There is also a wet bar in the center of the building. The water main is cast iron and enters in the northwest corner of the building, where the hot water heaters are located. Interior distribution piping is copper.

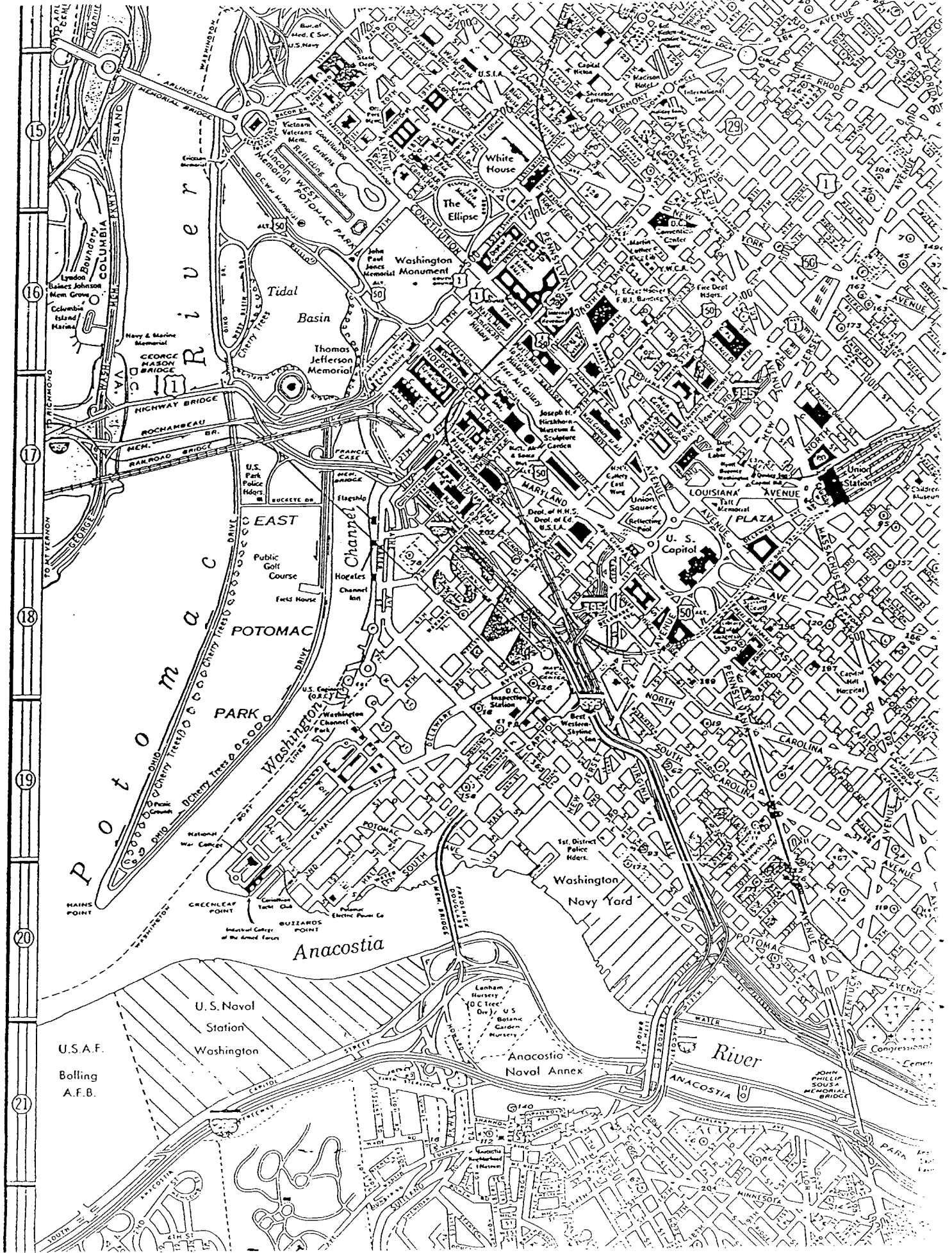

U.S.A.F.
Bolling
A.F.B.

EXISTING CONDITIONS

LOCATION ZONE CODE	DESCRIPTION	IMPROVEMENT DIST #
	EXTERIOR ENTRY SIGN	1 (A)
	REMOVE EXIST MERRAN	1 (B)
	REPAIR & RENOVATE PAVEMENT	1 (C)
	EXPAND DEFENSE BLVD	1 (D)
	NEW WAITER CTR	2
	ENTRY SIGN, SW	3 (A)
	ENTRY SIGN, SOUTH	3 (B)
	BLDG 72, PARKING/ROAD/ENTRY	4 (A) (B) (C)
	BLDG 72, SIGNS	5 (A)
	BLDG 72 "ONE WAY ST" SIGN	5 (B)
	BLDG 72 WEST SIDE	5 (C)
	EXTERIOR ST LIGHTS	8
	CONCEAL VEHICLE STORAGE AREA	9

ANACOSTIA RIVER

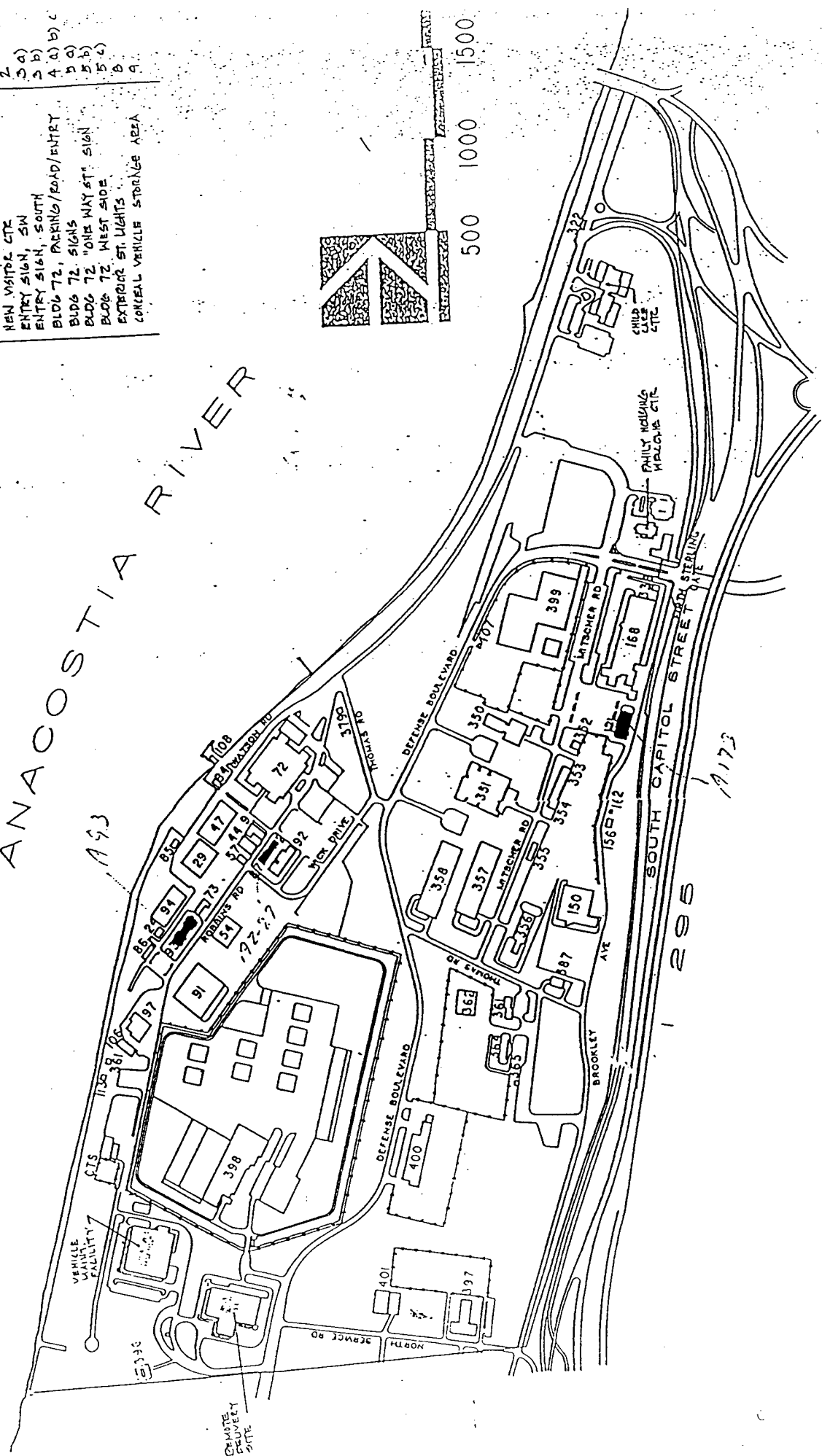
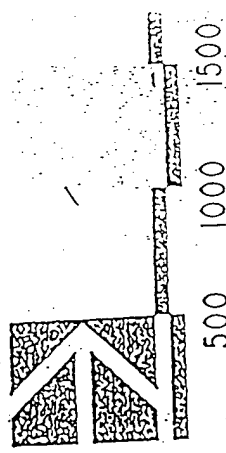

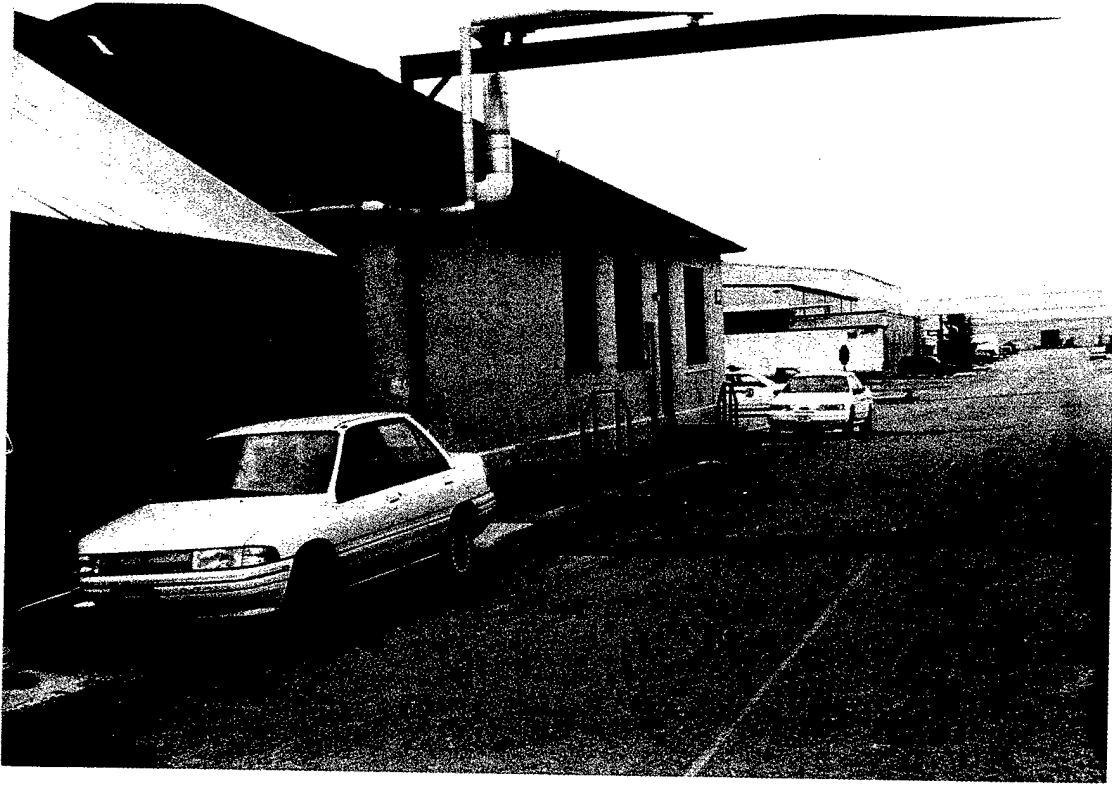

Figure
2

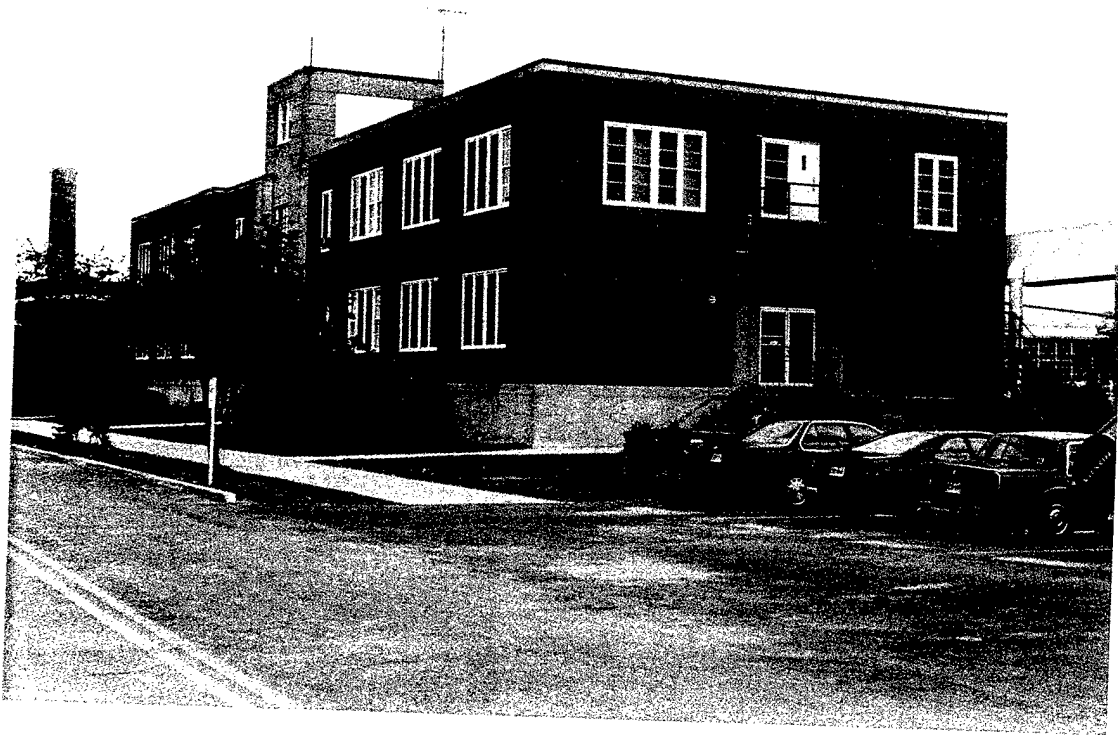

Figure
3

4. Demonstration Approach

4.1 Performance Objectives

The purpose of this ESTCP Demonstration Program is to show that this lining can be applied to the interior of drinking water systems in defense buildings and that this lining effectively prevents pipe corrosion and reduces levels of lead and other heavy metals in the water.

4.1.1. Minimal Operational Disruption

The contractor was required to perform the work in an expeditious manner and to minimize impact on tenants and their operations. The contractor had all materials on site at the onset of work and performed initial planning and inspections before water to the site was shut off. During the work, the contractor provided an alternative water distribution system using food-grade plastic hoses approved by the US Food and Drug Administration. Each piping system was reassembled and left in its original watertight condition after the process was completed, except for specified alterations.

4.1.2. Minimal Process Wastes

The contractor conducted all cleaning and lining work within a closed system. Used and unused abrasive grit, corrosion residues within the pipe, and paint wastes were collected in a trap at the end of the pipe being lined. The contractor removed all wastes from the site and disposed of them in compliance with all applicable regulations.

4.1.3. Reliability and Reproducibility

The contractor provided his own quality control procedures; reliably and reproducibly lined piping systems of different sizes, materials, layouts, and ages; and operated the process in a manner that was compatible with tenant operations.

4.2 Physical Setup and Operation

The contractor provided a "turnkey" operation. That is, he brought all materials and equipment needed for the work, inspected the piping system before work began, cleaned and lined the pipe with deliberate speed, restored the system to a water-tight condition, flushed the system and returned it to use. The contractor also installed a temporary drinking water distribution system in buildings A2-87 and A93 so that normal activities continued uninterrupted during lining operations.

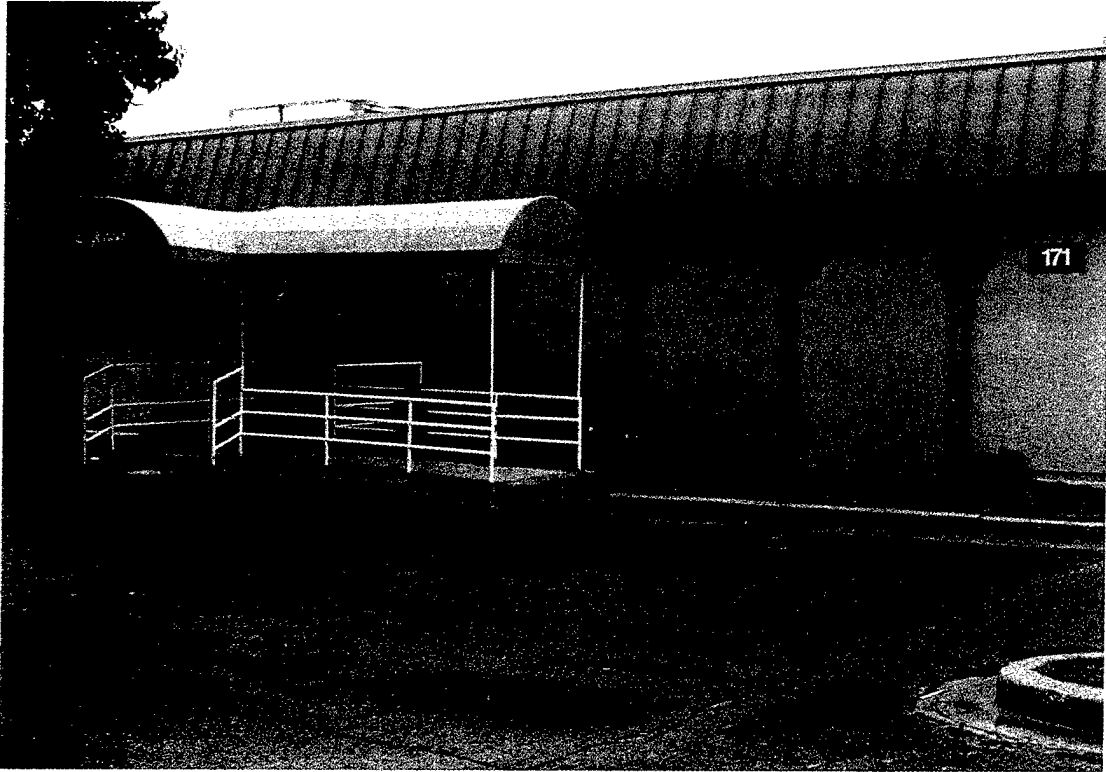

Figure
4

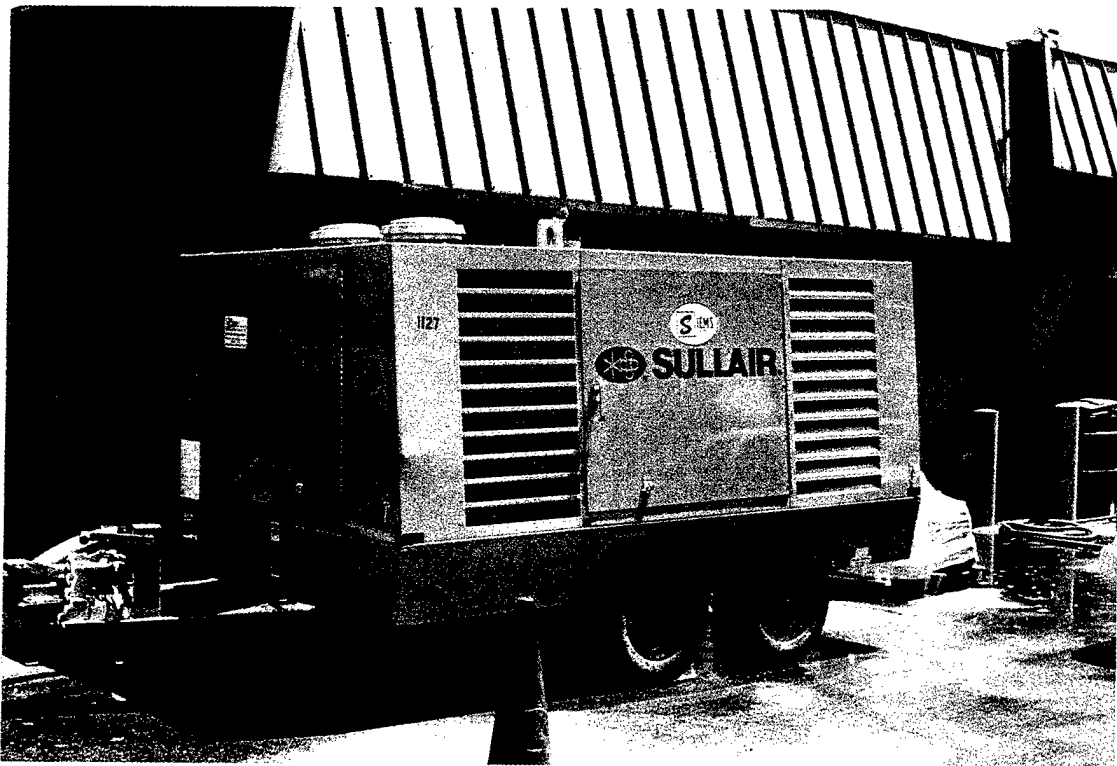

Figure
5

4.2.1. Equipment

A. A 900 cubic feet per minute (cfm) air compressor (FIGURE 5, page 16) provided the volume and velocity of air needed to effectively clean and line the pipe. This velocity was required to carry the blast grit through the pipe fast enough to clean the pipe and to provide an adequate anchor tooth for the epoxy lining.

B. In-line water and oil filters (FIGURE 6, page 18) were located between the equipment and point of entry to the piping system. The filters were periodically inspected and serviced to ensure delivery of uncontaminated dry air. Moisture was removed from the compressed air by an air aftercooler or dryer to prevent condensation in the piping. The maximum allowable size of airborne particles of oil or water was $0.75 \mu\text{m}$ (0.03 microns).

C. A heat exchanger (FIGURE 7, page 18) was used to raise the temperature of the compressed air and the pipe downstream from the aftercooler to provide further protection against moisture condensation in the piping. After reheating, the working air temperature was about $68 \text{ }^\circ\text{C}$ ($155 \text{ }^\circ\text{F}$) at an ambient air temperature of $27\text{-}32 \text{ }^\circ\text{C}$ ($80\text{-}90 \text{ }^\circ\text{F}$).

D. Air pressure regulators, in conjunction with a manifold system (FIGURE 8, page 19), were used to regulate the pressure of the air entering the pipe to be cleaned and lined.

E. A grit injector (FIGURE 9, page 19) was used to place the abrasive into the air stream at a measured rate.

F. A dust collector with an external filter bag (FIGURE 10, page 21) was installed at the discharge of the pipe and collected all spent grit, contaminated dust, and excess epoxy coating during the lining process.

4.2.2. Materials

A. Pure garnet, size 35/60, was used as the abrasive. This garnet was oil-free (as shown by the test in paragraph 2.1.2-C), clean and dry, contained less than 5 percent fines (smaller than 30 mesh by weight), and contained no materials which might remain embedded in the surface or create galvanic interaction with the pipe. The garnet left very little dust residue in the pipe. Abrasive blasting provided an anchor tooth of $37 \mu\text{m}$ (1.5 mils) for painting. To prevent contamination of the substrate, abrasives were used once and discarded.

B. The epoxy coating was the NRL Series 4 lining, manufactured by American Pipelining Corporation of San Diego, California, and tested and approved by NSF International for this purpose.

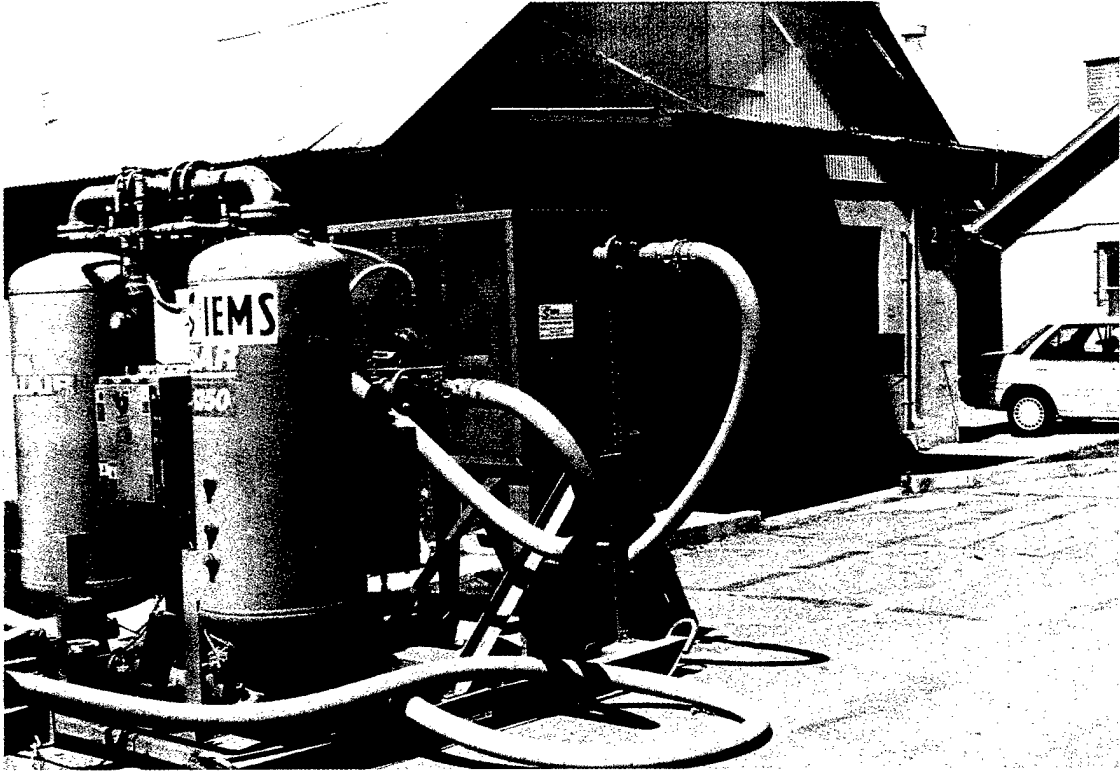

Figure
6

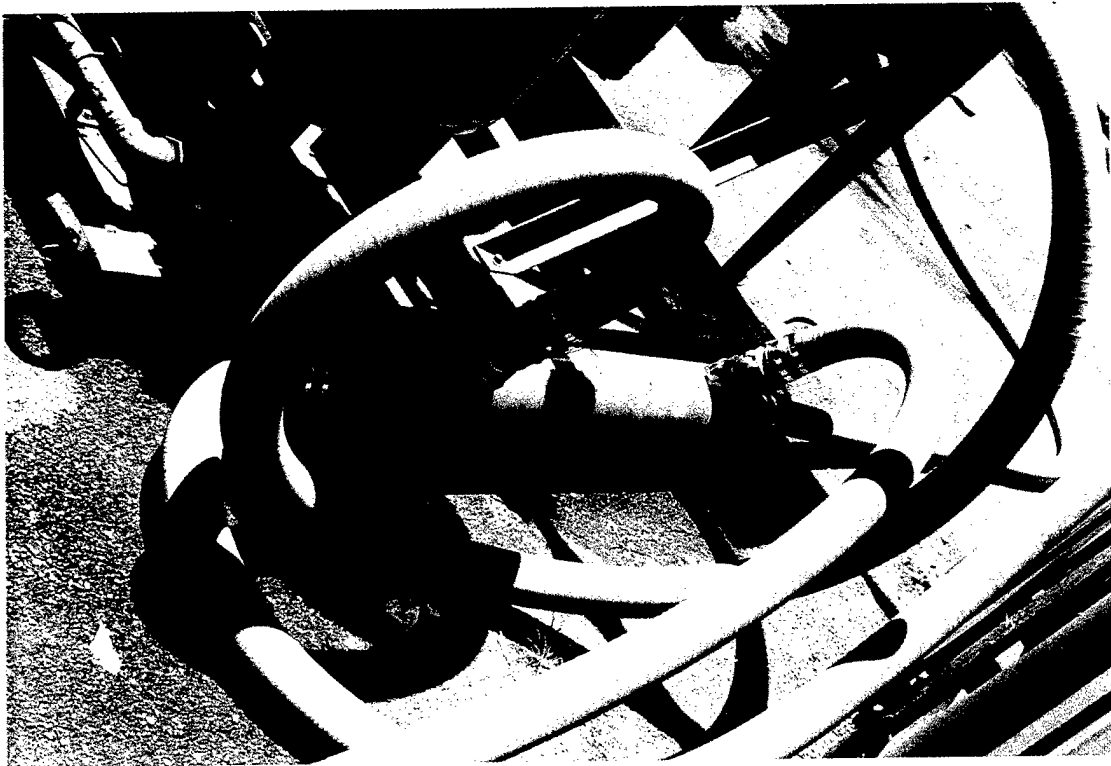

Figure
7

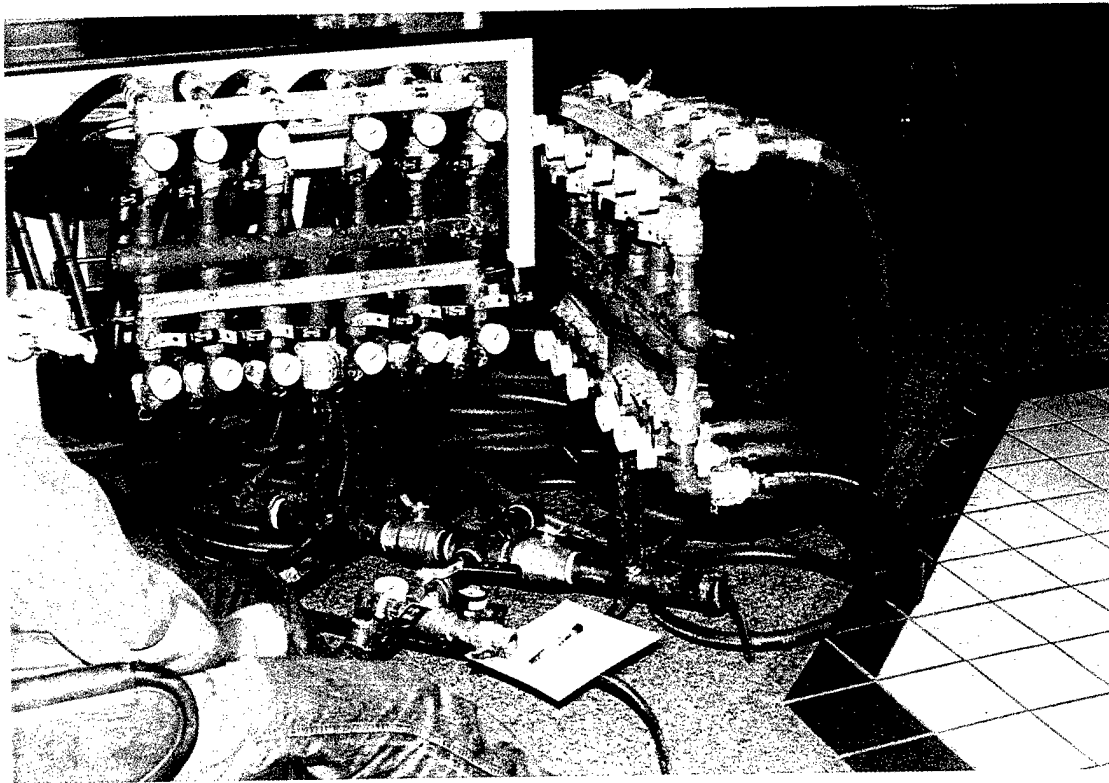

Figure
8

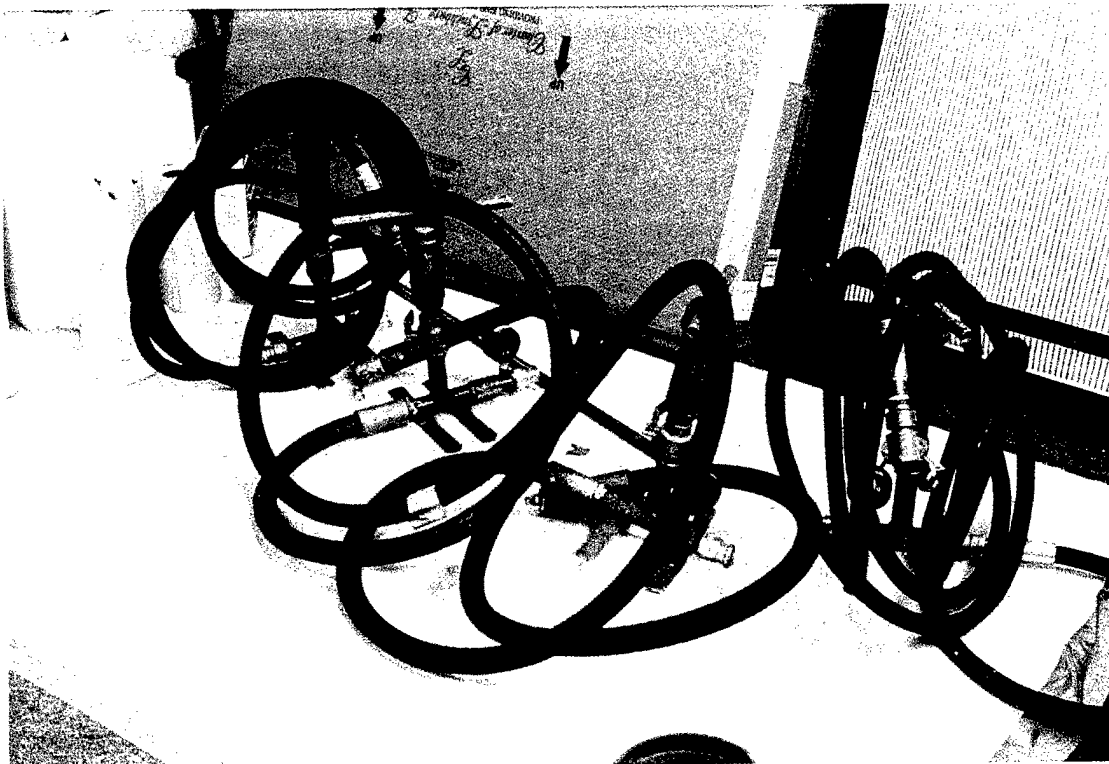

Figure
9



Figure
10

4.2.3. Evaluation of Pipe

A. Prior to beginning the lining process, the contractor ensured that the pipe to be lined was intact, had no holes, and had a minimum wall thickness of at least 50 percent of the original. The wall thickness was measured randomly on the pipe and within two feet downstream of the inside and outside of bends. The wall thickness of the pipe was measured at suitable intervals along the pipe, but at least every 50 feet. The wall thickness on vertical pipe was measured by taking four readings at 90° to each other.

B. The contractor identified dissimilar metals in the system that could become a potential cause of deterioration to the system. Dielectric unions were ultimately placed at all of these junctions.

C. The contractor determined the presence of non-standard layouts and items in the system that could affect its performance. Specifically, several dead-end runs of pipe were removed and numerous fixtures which might contribute levels of lead were identified but not replaced at that time because replacement was outside the scope of the contract.

D. The contractor identified the presence of corrosion in the system only at one junction between a galvanized pipe at a hot water heater. This was subsequently replaced and a dielectric union installed.

E. The contractor did not find asbestos insulation in or around the piping system.

F. The contractor found that lead in the system arose primarily from lead-based solder and brass faucets.

4.2.4. Initial Preparation of the Site

Since accurate drawings of the water systems were not available from the Naval District of Washington, the contractor developed these on his own (see Contractor's Production Reports in Appendix C). During this procedure it was noted that asbestos removal would not be required and only one area of corrosion was found which required replacement, a short run of galvanized pipe in building A171, the *Legends*. Several areas of old abandoned pipe that dead-ended were also removed from this building.

The number of "runs" necessary to complete each building was determined from the drawings. Adaptors and hoses for temporary water supply (FIGURE 11, page 23) were rigged for the BOQ and the Detention Facility, both of which remained in operation throughout the process. a temporary water service was not necessary at the *Legends*. Outdoor areas for the placement of the air compressor, dehumidifier, and dryer were determined as well as the hours available for work operations. Free access was allowed at the *Legends* and the Detention Facility while hours for cleaning and lining operations at the BOQ were restricted to hours when tenants were absent, about 0800 to about 1700.

The demonstration began on July 8, 1996 and continued until August 2. Work was not interrupted by weekends or holidays.

The *Legends* was lined first, followed by the Detention Facility, and lastly the BOQ. Scheduling was planned so that different operations could be performed in different buildings; for instance, lining was conducted in one building while temporary water was installed in the next building.

After the temporary water lines were installed in the Detention Facility and the BOQ, all valves and fixtures were removed from the pipe system. A small number of valves, fixtures, and piping sections whose thickness was less than 50% of original or were inoperable were replaced; most of these were in the *Legends*. All joints were converted to mechanical fittings to provide for reassembly after lining without application of heat from welding.

Air hoses were secured to every water pipe inlet (FIGURE 12, page 23) in each run segment and a connection/transition piece leading to the dust collector was installed to every water pipe outlet point within the run segment.

An initial air pressure test to check the integrity of the system was performed. Leaks were repaired as necessary and the system pressurized with air to 70 psi for 5 minutes and checked for pressure drops to validate system integrity.

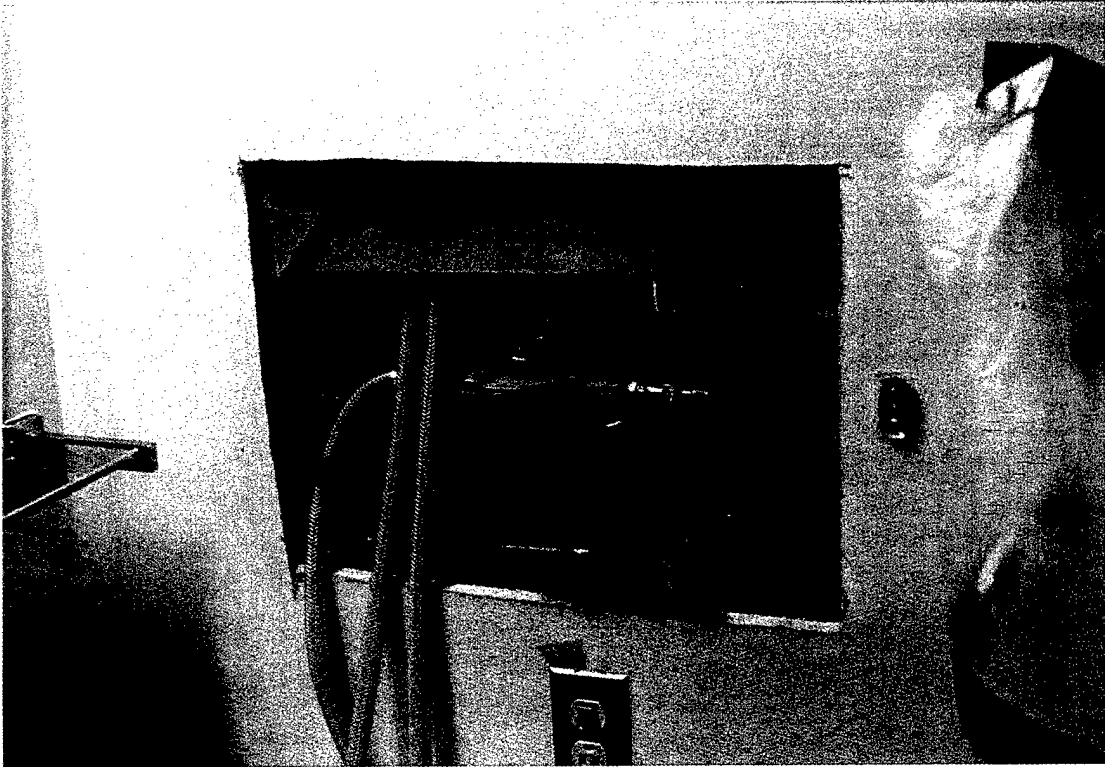

Figure
11

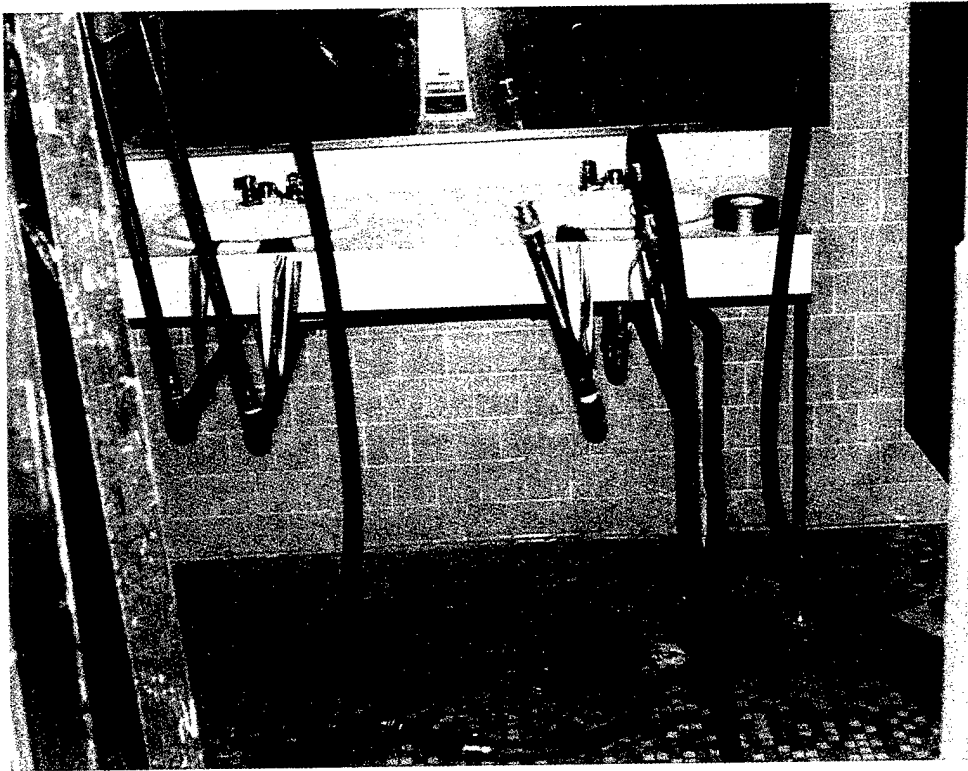

Figure
12

4.2.5. Cleaning

The piping was grounded to ensure that all static electricity was dissipated. A HEPA (High Efficiency Particulate Absorbent) bag filter was installed at the run outlet(s) to remove any particles created during the cleaning step. Hot, dry, oil free compressed air was forced through the run segment until the pipe was thoroughly dried. The pipe section was then cleaned by injecting garnet grit mix (one-third 16 mesh, two-thirds 80 mesh) into the flowing compressed air stream. The pipe run section was then purged with compressed air to clear dust and loose materials. Particulates were collected at the end of the pipe section in the filter and were disposed of in accordance with all applicable regulations. A pressure test was run on each segment to verify the integrity of the system after cleaning. The pipes all held 70 psi pressure for 5 minutes. Each section of pipe was visually inspected for cleanliness and proper anchor tooth pattern. The prepared surface had a clean blast appearance, and an anchor-tooth (not peened) surface profile of 37 μm (1.5 mils) which was validated (measured) at the pipe inlet and outlet with profile tape and a dial micrometer. The surface, when viewed using a magnification of 10x, was free from oil, grease, dust, dirt, mill scale, corrosion products, oxides, paint, and other foreign material.

4.2.6. Lining

Between cleaning and lining, hot, dry, oil-free compressed air, heated to a temperature high enough above the dew point to prevent condensation of moisture on the substrate, continued to flow through the pipe. The two components of the NSF International-approved epoxy paint were weighed out in the proper ratio, mixed thoroughly with a mechanical stirrer, and injected into the entries of each pipe segment in a quantity sufficient to coat the entire interior surface at twice the desired thickness to compensate for losses. Compressed air was then applied at the proper pressure and for the required duration to accomplish the interior coating of the piping segment. The emergence of paint at the end of the pipe segment was determined by observing it in a section of clear plastic pressure hose connected to the outlet line. At this point the air pressure was reduced to a low level to cease lining but provide enough warming to facilitate drying of the film. After adequate drying, a second coat was applied in the same manner as the first coat, but no later than 24 hours after the first coat. After the last coat of epoxy lining had been applied, hot air was passed through the pipe system for 12-18 hours to complete the curing of the epoxy lining. This process was repeated for each pipe run until the entire system had been coated.

The coated pipes were inspected visually as far into the pipe as was practical at each end to ensure uniformity and absence of film defects. Test pipes and clear hoses installed within the system being coated were inspected in the same way. All coated pipe was deemed acceptable after visual inspection, film thickness measurement, and knife adhesion testing.

4.2.7. Restoration of the Piping System

After the paint had dried sufficiently, all valves and other make-up pieces were re-installed. A pressure test was done with compressed air to test the integrity of the piping, valves and joints. The pipe systems all held 70 psi pressure for 5 minutes. Repairs were necessary only at one sink area at *Legends*. All fixtures and appliances were reconnected, potable water introduced into the system at its normal operating pressure, and the entire system was flushed with a minimum of twenty-five volumes of potable water.

The entire system was then filled with potable water and allowed to stand without disturbance for twelve hours, followed by flushing again with a minimum of twenty-five volumes of potable water and then allowing to stand without disturbance for twelve to eighteen hours prior to sampling.

4.2.8. Sampling and Inspection System

Sampling and inspection of the coating materials and processes consisted of the following steps. These are documented in the Contractor's Production Reports in Appendix C.

A. Sampling and inspection of materials:

(1) Epoxy paint designated APL 2000: Component 1 (base), Lot 60196; and Component 2 (hardener), Lot LC15B12446; date of manufacture, June 1996 for both.

(2) Grit used for cleaning and establishing an anchor tooth profile: 16 mesh from Emerald Creek, Post Office Box 90, Fernwood, Idaho 83830 and 80 mesh from GMC, Australia; both passed the oil sheen test in 2.1.2-C.

(3) Quality of air used: Oil content < 10 ppm, water content < 1%.

B. Inspection of the prepared substrate after blast cleaning and prior to lining: Anchor tooth profile - 1.5 mils; contaminants such as dust, water, oil, or scale - none observed; and absence of leaks in the system by pneumatic pressure test at 70 psi for 5 minutes - pass.

C. Inspection of the lining: The inlets and outlets of each lined pipe section as well as spool pieces and clear hose sections of the section were examined visually. The lining thickness was measured by removing dry film from the plastic hose "witness" sections and measuring with a micrometer. All test samples were within specification parameters of 150 and 225 μm (6-9 mils).

4.3 Sampling Procedures

Both the on-site monitoring method and the reference analytical method require that water stand undisturbed in a piping system for at least 18 hours before samples are taken. At that time

a one-quart sample is collected in a polyethylene bottle which has been specially cleaned to remove heavy metal contaminants. The bottles were supplied ready-to-use by the confirmation laboratory. After collecting the sample the bottle was capped and shaken to ensure complete mixing. For the on-site monitoring method, one-tenth of an ounce of water was transferred to the disposable sensor in the testing device. For the reference method the entire sample (or the quart sample less the 0.1 ounce) is sent to the reference laboratory. Samples were taken from hot and cold outlets of sinks where quality is more of a concern than from urinals and showers. Test data for the field method was taken from the samples collected for the reference method in order to get a direct comparison of the results.

4.4 Analytical Procedures

Two analytical methods were used to test water from lined pipes for lead content. To measure the concentration of lead in drinking water from the lined piping on site we used a potentiometric stripping analyzer, the "Metalyzer 3000" manufactured by the Environmental Technologies Group, Inc., 1400 Taylor Avenue, P. O. Box 9840, Baltimore, MD 21284-9840; contact Rick Priddy, phone 410-321-5219 or 410-321-5200, fax 410-339-3213. Our unit was a prototype or "beta" unit. [This model has since been redesigned by the manufacturer and is now being sold as a production model, the "Metalyzer 5000."] Our unit (no apparent serial number; NOSC property number NOSC USN 66001 *PB12709*) used software version 1.12. This unit gives a direct reading in about 2 minutes for lead, cadmium, and copper.

Secondly, samples were collected and shipped to an EPA-approved laboratory where they were tested⁴ by EPA Reference Method EPA 239.2. The limit of this method is 5 $\mu\text{g/L}$; amounts less than that are reported as ND (not detectable). The precision of this method is ± 1 $\mu\text{g/L}$.

5. Performance Assessment

5.1 Obtaining Samples of Tap Water for Analysis of Lead

Taps in the buildings to be lined were not used for 24 hours before sampling, as specified in EPA Reference Method EPA 239.2. This precaution was not sufficient to ensure that each sample represented water lying undisturbed in the area being sampled. In addition, subsequent analysis of the data indicates that each sample is compromised to some extent by concurrent sampling at nearby faucets.

Analyses of lead by the EPA Reference Method, in the three demonstration buildings before lining, are given in Table 2. Each number denotes a single measurement on a separate water sample; no averages or means are reported. The buildings were in daily use during the sampling period, and differences in the March and September data are caused by the frequency and volume of water drawn at each sampling point. Specific difficulties in sampling were:

Table 2. Baseline Lead Determinations, March and September, 1995

Sample Number ¹	Location ²	September	March
Building A171			
33	Kitchen sink 1	6	6
17	Kitchen sink 2	ND	9
31	Main men's sink 1	52	17
1	Main men's sink 2	17	16
28	Main men's sink 3	5	35
37	Main women's sink 2	9	13
44	Old men's sink 1	23	410
32	Old men's sink 2	24	670
36	Old women's sink 1	69	380
40	Old women's sink 2	272	90
Building A93			
10	First floor men's sink 1	10	
26	First floor women's sink 1	13	9
19	First floor women's sink 2	8	10
9	First floor water fountain	ND	7
49	First floor kitchen sink	15	21
25	Room 101	8	30
46	Room 102	ND	8
35	2nd floor water fountain	3	
Building A2-87			
39	A2 Men's sink 1	3	
8	A2 Men's sink 2	23	9
23	A2 Men's sink 3	4	100
42	A2 Water fountain	4	21
20	A87 Cell 1 water fountain	131	70
7	A87 Cell 2 water fountain	212	20
18	A87 Water fountain	68	15
15	A87 Janitor's room	5	31
5	A87 Men's sink 1	ND	11
48	A87 Men's sink 2	5	
34	A87 Men's sink 3	3	9
12	A87 Women's sink 1	69	41

Note 1: Numbers were assigned randomly to preclude bias in handling and analysis.

Note 2: In rooms with more than one sink, sinks are numbered from the left.

5.1.1 *Faucets out of Service.* Certain faucets were out of service, and water had been standing in the taps far longer than 24 hours. For example, in Building A171, the old men's sinks 1 and 2 and the old women's sinks 1 and 2 showed extraordinarily levels of lead because these taps had not been used for some months before the March, 1995. These taps were not used again until the September, 1995 sampling, and lead levels again were high, but not as high as the first readings.

5.1.2 *Interference between Taps.* Sampling from one tap affects the water in adjacent taps. Taking the stipulated 1-Liter sample from a 1/2-inch pipe drains 25.9 feet of pipe; water so far back in the pipe feeds other taps as well, and water subsequently sampled from nearby taps will be diluted by fresh water drawn into the feeder lines by the first sampling. Careful analysis of our data on the order of sampling and the measured lead levels reveals a step-wise dilution in measured lead levels. This is seen most clearly in the old sinks in building A171.

5.1.3 *Fixtures.* Fixtures add significant lead to the sample. The Safe Drinking Water Act of 1986 requires that the lead content of fixtures must be less than 8 percent. Nevertheless, old fixtures abound, and it has been estimated that up to 33 percent of the first-draw sample may contain lead leached from the faucet. Furthermore, it is estimated that 20 faucet volumes of water must be passed before the faucet effect is eliminated.⁵

5.1.4 *Continuing Use.* Despite our best efforts, we cannot be completely sure that all tenant activities came to a halt during the sampling period. In particular, Building A2-87 is staffed around the clock.

5.2 Performance Data

5.2.1 *Building A171.* Some modifications to the piping system were necessary before work began: Repairs were necessary at one sink area; long dead-end runs of pipe were disconnected; and a section of galvanized pipe near the north hot water heater was removed and replaced by copper piping. The piping was divided into three runs, and check valves were used to define the limits of each run and prevent paint from blowing out of the intended area. The three runs were completed between July 12-16.

5.2.2 *Building A2-87.* A temporary water distribution system was installed in the ceiling. The piping was divided into two runs, separated by a check valve, the break being placed in the hallway north of the mechanical room. Work was completed without incident between July 18-20.

5.3.3 *Building A93.* To accommodate tenants' wishes, work was limited to the period 0800-1600. Temporary hot and cold water systems were installed for all sleeping rooms, the kitchen and the clothes washers. The piping system was divided into three segments: from the east end of the building to the mechanical room; the mechanical room, including this room, halfway to the west end of the building; and from the end of segment two to the west end of the building. The three runs were lined between July 23 and August 2.

5.3 Followup Assessments After Lining

Results of the analyses after lining are given in Table 3. Each number denotes a separate water sample; no averages or means are reported. Numbers in bold exceed the legal limit for lead in water of 15 micrograms per liter ($\mu\text{g/L}$). Testing was performed according to the methods stipulated in Section 4.4. In several cases duplicate samples were taken from the same source and analyzed; no pair of values differed by more than 3 $\mu\text{g/L}$.

5.3.1 *Calibration of the Metalyzer 3000.* Sixteen samples (denoted C) collected after lining gave values for lead between 5 and 50 ppb by both the Metalyzer and EPA Standard Methods, as shown in Table 3. A linear regression analysis on these 16 data pairs yielded a regression coefficient (R^2) of 0.94 and a standard deviation of 3.5. Thus values from the Metalyzer can be regarded as ± 3.5 ppb different from the EPA Standard Method. The regression coefficient and standard deviation are likely better than this because 11 pairs of values (denoted x) were excluded from this calculation (see Table 3); in each of these pairs the value found by the Metalyzer was below its detection limit (5 ppb) and 9 of the 11 values from the EPA Standard Method were also below 5 ppb.

5.3.2 *Building A171.* This building was chosen for a detailed assessment of the sources and concentrations of lead in water. The building was temporarily out of use, giving us freedom of movement and the ability to control the water flow in the facility at all times.

Legends was divided conceptually into three suites. Refer to the plumbing diagram in the contractor's production report (Appendix C) to aid in visualizing the suites.

Suite 1 contains the main bathrooms at the north end, which have three sinks apiece, women's 1, 2 and 3 and men's 1, 2 and 3. Each is within about 20 feet of where the main enters the building.

Suite 2 is the kitchen area and contains three sinks, 1 (left), 2 (center), and 3 (right). Each is within about 60 feet of where main enters the building.

Suite 3 consists of the unused bathrooms and a bar. The bathrooms have two sinks each, women's 1 and 2 and men's 1 and 2; the bar has one sink. Each bathroom sink is within about 100 feet of where the main enters the building, and the bar sink is perhaps 120 feet from this spot.

Table 3. Metal Determinations, August, 1996, after Lining

Sample Number ¹	Location	Pb ² (EPA Method Pb) ³	Cd ⁴ (ppb)	Cu ⁵ (ppb)	Regression
Building A171					
78	Kitchen sink 1 hot water	45.3 (46)	<5	3112	C
94	Kitchen sink 1 hot water (retest)	56.4	<5	3145	
63	Kitchen sink 2 hot water	20.9	<5	<70	
74	Kitchen sink 2 cold water	42.5 (46)	<5	216.8	C
62	Kitchen sink 3 hot water	<5	<5	5754	
84	Kitchen sink 3 cold water	<5 (12)	<5	514.8	x
80	Women's sink 2 cold wtr	11.0 (13)	<5	493.7	C
81	Bar sink cold water	7.5 (7)	<5	385.8	C
Building A93					
82	Room 101 cold water	8.9 (3)	<5	<70	C
76	Room 103 cold water	6.3 (<1)	<5	<70	
75	Room 104 hot water	9.5 (3)	41.5	271.8	C
69	Room 105 hot water	7.6 (7)	24.6	<70	C
68	Room 106 cold water	<5 (<1)	<5	<70	x
71	First floor water fountain	6.1 (10)	<5	72.4	C
66	First fl men's sink 1 hot water	<5 (3)	<5	<70	x
67	First fl men's sink 2 cold water	<5 (4)	<5	<70	x
64	Room 208 cold water	<5 (1)	<5	<70	x
83	First fl kitchen sink cold water	15 (19)	<5	105.8	C
	Room 210 cold water ⁶	(<1)			
91	Room 210 hot water	5.3 (1)	<5	<70	C
86	Room 211 hot water	6.5 (2)	<5	116.5	C
90	Room 211 cold water	<5 (2)	<5	<70	x
92	Room 212 hot water	<5 (10)	<5	<70	x
93	Room 212 cold water	<5 (<1)	<5	<70	x
88	Room 213 hot water	9.8 (8)	<5	<70	C
85	Room 213 cold water	<5 (2)	<5	<70	x
87	Room 214 cold water	<5 (1)	<5	<70	x
65	Second fl kit sink hot/cold water ⁷	6.4 (<1)	<5	<70	

Table 3. Metal Determinations, After Lining (continued)

Sample ¹ Location	Pb ² (EPA Method Pb) ³	Cd ⁴ (ppb)	Cu ⁵ (ppb)	Regression
Building A2-87				
70 A87 Water fountain	15.8 (18)	<5	<70	C
72 A87 Cell 1 hot water	11.2 (5)	<5	<70	C
73 A87 Cell 1 cold water	<5 (2)	<5	<70	x
77 A87 Cell 2 hot water	15 (12)	<5	<70	C
79 A87 Cell 2 cold water	8.8 (5)	<5	120.7	C

Note 1: Numbers were assigned in sequence by the Metalyzer 3000.

Note 2: Results from the Metalyzer 3000; limit of detection 5 ppb.

Note 3: Results from the reference laboratory using EPA Reference Method EPA 239.2; limit of detection 1 ppb.

Note 4: Results from the Metalyzer 3000; limit of detection 5 ppb.

Note 5: Results from the Metalyzer 3000; limit of detection 70 ppb.

Note 6: Not measured with the Metalyzer 3000.

Note 7: This was a single-control, pivoting handle faucet.

In each suite, we determined the order in which supply water flows to the taps, determined as precisely as possible the length of pipe between taps, and determined if a 100-mL sample can be obtained without compromising other samples.

a) The main bathrooms have men's and women's sinks back-to-back. It is possible to sample from a tap nearest the water supply (men's 1) and then from a tap which is both farthest from the water supply and about 2½ feet from the first tap (women's 3). We did not sample from back-to-back taps. Thus two undisturbed samples from this suite were taken each day.

b) In the kitchen, two taps are about 6 feet from one another and the third is across the room. We sampled from only one of the former. We obtained an undisturbed sample from sinks 1 (left) and 3 (far right) taps each day, including the tap which gave the high readings in September, 1996.

c) In the old bathroom suite, the situation is essentially the same as in the main bathroom suite, although the geometry is different. The men's and women's sinks are back-to-back. It is possible to sample from a tap nearest the water supply (men's 1) and then from a tap which is both farthest from the water supply and about 2½ feet from the first tap (women's 2). The bar is about 20 feet from the bathrooms and gave an undisturbed sample after the bathrooms were sampled. Thus three undisturbed samples from this suite were taken each day.

Cold water was sampled on two successive days, February 27 and 28, 1997, and samples were analyzed in the Metalyzer 3000. We began sampling at the area closest to the water main and continued to the area most remote from the water main; that is, we sampled the main (north)

After the February 27 testing was completed, the lines were again flushed for approximately 20 minutes, closed and allowed to remain static for about 15 hours. The sampling was repeated as before except that the old (south) women's sink 2 was sampled prior to the old (south) men's sink 1 and the bar sink was not sampled. At the end of the second flushing a 1 liter sample was taken from the kitchen sink 3 (far right) to serve as a baseline of incoming (from main supply) water. The results of this testing are given in Table 5.

Table 5. Day 2 (February 28) Samples: Lead (Copper) Concentrations, ppb

Sample Description	10 mL	100 mL	300 mL	1 Liter
Main men's sink 1	8.5 (72.9)	15.8 (<70)	5.9 (<70)	11.2 (<70)
Main women's sink 3	17.2 (<70)	<5 (<70)	6.9 (<70)	<5 (<70)
Kitchen sink 2	<5 (<70)	16.2 (<70)	5.2 (<70)	6.3 (<70)
Kitchen sink 1	14.1 (<70)	26.6 (<70)	13.2 (111)	<5 (<70)
Old men's sink 1	42.2 (140.8)	14.3 (<70)	<5 (<70)	12.6 (<70)
Old women's sink 2	9.1 (<70)	6.6 (<70)	12.7 (<70)	15.9 (<70)
Kitchen sink 3	-	-	-	<5 (<70)

Even after the second day's sampling, lead levels in three samples remained surprisingly high. Although all measurements conform to EPA Requirements [within one standard deviation (3.5 ppb)], it is reasonable to expect that a fully-lined piping system should show no lead at all in the water it contains. In this case, however, it is likely that some dust residue from the pipe cleaning operations remained in the pipe and was incorporated in the paint, creating a small source of lead. If the building were in constant use, this reservoir would be exhausted by now and lead levels would be uniformly below the limit of detection of the Metalyzer 3000.

5.3.3 *Building A2-87*. This building, a detention facility, is in use continuously around the clock. Therefore samples of water were taken for analyses on April 8, 1997 at 0500 to 0530 in order to increase likelihood of having 6-8 hours of low or non-usage. Even in spite of this it is assumed that the A2 men's restroom saw limited use during the night. Lead and copper determinations were made using the Metalyzer 3000 unit. Results are given in Table 6 below. All five of these locations were also sampled in March and September 1995, before lining.

As can be seen from these data, detectable concentrations of lead and/or copper are found in the first 10 or 100 mL of sample, indicating that metals are clearly associated with fixtures. After water from the fixtures is drawn, none of the remaining water contains a detectable amount

of lead, as would be expected for a building in constant use. The water fountain, which has an internal reservoir, shows lead in the first 300 mL of sample.

Table 6. Samples: Lead (Copper) Concentrations, ppb

Sample Description	10 mL	100 mL	300 mL	1 Liter
Cell 2 water fountain	21.9 (<70)	<5 (<70)	-	-
A87 Women's sink 1	26.4 (<70)	<5 (<70)	<5 (<70)	-
A87 Men's sink 3	<5 (<70)	<5 (<70)	<5 (<70)	<5 (<70)
A87 Water fountain	<5 (<70)	10.2 (362.9)	<5 (80.5)	-
A2 Men's sink 3	18.7 (<70)	14.8 (<70)	<5 (<70)	<5 (<70)

5.3.4 *Building A93*. No followup testing was conducted in this building.

5.4 Conclusions

Analyses of lead in water using the Metalyzer 3000 correlate with EPA Reference Method EPA 239.2 over the range of 5 to 50 ppb. The regression coefficient R^2 over this range is 0.94 and one standard deviation is ± 3.5 ppb.

Obtaining a statistically-significant number of undisturbed samples of water at one time is difficult. In bathrooms and kitchens where sinks are close, samples from one tap draw on water supplying a neighboring tap. Dilution effects are seen in sampling and must be considered when analyzing data.

Fixtures contribute a significant amount lead to the sample. Water samples which separately reflect the water in the fixture, the water in the feeder lines, and the water in the main are an effective way to identify the source of lead.

Dust, created when the pipe interior is cleaned by abrasive grit, must be scrupulously removed from the pipe before the liquid lining is introduced. The dust has a high surface area and, if entrained in the lining, will leach heavy metals into the drinking water. Excessive amounts of dust will prevent adhesion of the lining to the pipe and cause premature failure of the lining.

The NRL Series 4 epoxy lining stops leaching of lead into drinking water piping systems and maintains lead levels in water below EPA limits (Tables 5 and 6).

5.5 Technology Comparison

Other technologies to place linings within piping systems are available.

The technology which competes most directly with the demonstrated process is available from Union Carbide Industrial Services Company of Houston, Texas. In this process, the UCISCO process, air inlets are established at each end of pipe to be lined. Two hard rubber balls are introduced at one end and a fast-drying lining is placed between the balls. Air pressure is used to move the two balls to the far end of the pipe; pressure is reversed and the balls are propelled back to their starting point. Paint is squeezed onto the pipe walls during both passes. The balls must be returned to their starting point and removed from the pipe before the paint sets, gluing them in place.

Preformed solid polymer films may also be inserted into pipes. In one case, a cable is used to pull a deflated plastic liner through a pipe; hot air then inflates the liner and, in the reverse of the shrink-wrap process, heat-bonds it to the inner surface of the pipe. The liner must be punctured at each branch from the main line to restore flow to the branch; if the branch is lined in a similar way, there is no way to bond the liners at the joint. A similar process, the Insitu-Form process, uses a resin-soaked fabric in place of the plastic liner; after insertion heat is used to cure the resin and hold the liner in place. Limitations to this process are the same.

These methods are suitable only for long unbroken runs of pipe which have a constant diameter and lack sharp bends. Municipal underground sanitary sewers and fuel distribution systems at airfields are examples of where this type of pipe configuration may be found.

It is also possible to blow a thick slurry of cement in water through a pipe to produce a cement lining. Although sometimes used in metal pipes in the vain hope that the alkaline cement will passivate the metal and prevent its corrosion, this process is most often used in underground cement sewer and drainage pipe systems.⁶

Chemical treatments for water which reduce the rate of extraction of lead from the pipe are also available.^{7,8}

Faucets which contain no lead are commercially available.⁹

6. Cost Assessment

6.1 Cost Performance

The costs of using the lining are entirely installation costs. Once installed, the lining requires no maintenance. The coating is expected to last 30 years in residential, office, and light industrial applications. These projections are also based upon nine years of experience with these coatings on aircraft carrier sanitary piping systems, and on six years of commercial activity

with epoxy coatings in residential drinking water systems. The government assumes no future liability as long as the lining has been approved by NSF International under ANSI/NSF Standard 61 and has been applied properly. Spare parts and training of water system operators are not issues.

The contractor furnishes all labor, equipment and supplies. The contractor does what little site preparation is necessary. Cleaning and painting are done within the pipe system and hoses (which may attain 60 psi). There are no requirements for more than standard worker safety and environmental precautions, and no extraordinary costs are incurred in this area.

The actual costs of this demonstration project are broken down In Table 7:

Table 7. Cost Data Table

Cost Category	Cost
Materials	\$ 40,265
Direct Labor	8,628
Other Direct Costs	15,339
Manufacturing Overhead	4,794
General & Administrative	26,844
TOTAL	\$ 95,870

Categories in Table 7 are defined as follows:

Direct Material (42%): Garnet blasting grit; replacement plumbing materials, paint. The principal component of the price of the paint is the cost of having it tested and approved by NSF International.

General & Administrative (28%): Administrative costs, payroll accounting, taxes.

Other Direct Costs (16%): Compressor rental and fuel, hoses, fittings, transportation of crew to job site; meals and lodging at the job site.

Direct Labor (9%): Wages, protective clothing & equipment; housing and per diem for workers on site.

Manufacturing Overhead (5%): Freight of reusable equipment to job site and return to contractor's home base.

Costs are highly dependent on the piping system being lined. The amount of work being done at one time affects costs, because it allows overhead costs to be spread over several buildings. For planning purposes in the continental United States in 1997 estimate \$75 per linear foot of pipe (diameter not important) and three days per structure. Costs to install new piping are influenced by geographical variances in labor and materials. Detailed pricing information may be found in trade manuals such as the *Plumber's Pricing Manual*¹⁰.

6.2 Cost Comparisons to Conventional and Other Technologies

Quantitative cost savings are very difficult to state in general terms. Factors which affect cost are:

6.2.1 Factors Related to Any Method of Rehabilitating Pipe:

- A. Pipe may need to be replaced because it has corroded, or because it contains lead solder or other proscribed materials. Methods of construction determine the ease of tearing out and replacing piping.
- B. Restoration of pipe system to code. If deviations are found such as incompatible metals (*i.e.*, a galvanized pipe section in a copper pipe system), lengths of dead-end pipe, or a section of smaller-diameter pipe connecting two sections of larger-diameter pipe), they must be repaired before work begins so that subsequent cutting and repair of lined pipe is precluded.
- C. If asbestos insulation is found, it must be removed.
- D. Disposal of old pipe, insulation, and related materials.
- E. Labor costs.
- F. The loss of use of the building during pipe replacement.

6.2.2 Factors Related to the Demonstrated Technology:

- A. Thickness of paint to be applied to the interior of the pipe.
- B. Metal from which the pipe is made.
- C. Spot repairs to pipe before coating begins.
- D. The need to install a temporary drinking water distribution system.
- E. Walls and floors may be penetrated and subsequently repaired. Drywall is easily cut and removed, and easily repaired. Other materials such as brick, wood, plaster or ceramic tile are more expensive to alter.

F. The amount of time that the building can be made available to the contractor should be as long as possible. For instance, if tenants allow work to proceed only between 0800 - 1600, the number of days to complete work will be increased.

G. Costs related to the time that the building is out of service are separate and must also be considered.

6.2.3 Costs of Replacing Pipe in Building A93, the Bachelors Officers Quarters

The actual cost of replacing all piping in Building A93 is \$114,213.00. Labor was provided by the Public Works Department at the Naval District of Washington. This cost is greater than the cost of lining all three buildings in this demonstration project, which was \$95,870.

7. Regulatory Issues

7.1 Approach to Regulatory Compliance and Acceptance

Materials in contact with drinking water must be tested and approved by NSF International (Ann Arbor, Michigan) for compliance to ANSI/NSF Standard 61, *"Drinking Water System Components - Health Effects."* NSF International, a not-for-profit organization, is the only firm authorized by the Environmental Protection Agency to test and approve materials for contact with drinking water. The testing consists of three parts: A review of the properties and history of the ingredients of the lining; application of the lining to pipe, extended contact with water, and tests of the water to ensure nothing has been extracted into it; and examination and certification of manufacturing facilities to ensure that the lining is not contaminated with extraneous material. Because of the requirement that manufacturing facilities must be approved, only manufacturers can obtain NSF certification. To make certification more rapid and less expensive for manufacturers, NRL supported the first two phases of the certification procedure with non-ESTCP funding.

The NRL lining has been licensed exclusively to American Pipelining Corporation (address in Appendix A, page 45). American Pipelining identifies this lining by their product number APL-2000 and has obtained NSF International certification for domestic hot and cold water.

Defense Department users are cautioned about the selection of coatings for contact with potable water. Many coatings are offered commercially for this purpose, but because their compositions are proprietary and likely to change, it is not possible to describe all of them here. The NRL Series 4 coatings are recommended, for they have been developed by the Naval Research Laboratory specifically for this application and have passed all necessary health and safety tests.

There are no regulatory issues unique to the installation of the lining. Good industrial hygiene must be practiced to avoid contaminating the lining, and the piping system must be flushed before use. Once installed, the lining requires no maintenance or repair, and spare parts and training DoD personnel for this work is not an issue.

8. Technology Implementation

8.1 DoD Need

Several Defence facilities do not comply with EPA and Defence regulations on lead in drinking water. Several buildings have been taken out of service, and bottled water is brought into many others at substantial cost. There is a need for a fast, economical way to rehabilitate these buildings.

8.2 Transition

Appendix D contains technical information extracted from the Request for Proposals used in this Demonstration Program. Defense activities are urged to examine this, modify it to suit local needs, and use it directly in their own solicitations or RFPs.

9. Lessons Learned

The following is a list of lessons learned during the execution of this demonstration.

- A. Accurate drawings of the potable water systems makes planning and scheduling more efficient, thus reducing uncertainty in costs.
- B. Fixtures which leach heavy metals into the water should be identified and designated for replacement, because they are not lined in the process and they will continue to contribute substantial concentrations of heavy metals to water.
- C. The use of a borescope is impractical due to the time involved for drying and the many branches which can be in any single run. Therefore the use of plastic hose "witness" blanks facilitates checking film appearance, drying, and thickness.
- D. Care must be taken to remove all dust after grit blasting and before lining.
- E. Requests for Proposals and award of a contract consume a great deal of time. Engineering Field Activities should remain involved in all phases of the contracting process so as to expedite this process and to ensure smooth scheduling at the work sites.

10. References

1. *NSF Listings: Drinking Water Additives - Health Effects*, May 7, 1996. NSF International, 3475 Plymouth Road, PO Box 130140, Ann Arbor, MI 48113-0140, phone 313-769-8010, fax 313-769-0109.
2. ANSI/NSF Standard 61, *Drinking Water System Components - Health Effects*, published by NSF International, Ann Arbor, Michigan.
3. ASTM Method D-3359, Method for Measuring Adhesion by Tape Test, published by the American Society for Testing and Materials, 100 Barr Harbor Drive, W. Conshohocken, PA 19428-2959, phone 610-832-9717, fax 610-832-9666.
4. This Method is found in *Methods for Chemical Analysis of Water and Waste*, 600/4-79-020, March 1983, available from the US Environmental Protection Administration.
5. *"Lead Control Strategies,"* American Water Works Association, Denver, CO, 1990.
6. H. Oulette and M. Schrock, "Rehabilitation of Sanitary Sewer Pipelines." *Transportation Engineering Journal of the American Society of Civil Engineers* **107** (TE4), 497-513 (1981).
7. *"Lead and Copper Rule Guidance Manual, Volume II: Corrosion Control Treatment,"* Publication EPA 811-B-92-002, Environmental Protection Administration, September 1992.
8. *"Control of Plumbosolvency in Building Plumbing Supplies,"* by V. F. Hock, H. Cardenas, K. W. Smothers, and E. D. Zelsdorf. Technical Report 96/74, Construction Engineering Research Laboratories, US Army Corps of Engineers, P. O. Box 9005, Champaign, IL 61826-9005 July 1996.
9. *"Lead at the Tap: Sources and Control,"* by R. G. Lee, W. C. Becker, and D. W. Collins, American Water Works Association, Denver, CO, July 1988.
10. *Plumber's Pricing Manual*, published by Trade Service Corporation, 10996 Torreyana Road, San Diego, CA 92121, 800-854-1527.



Appendix A

Points of Contact

The following individuals participated in all or part of the demonstration:

Dr. Robert F. Brady, Jr.⁺
Dr. James D. Adkins*
Code 6123
Naval Research Laboratory
Washington, DC 20375-5342
tel 202-767-2268,⁺ -2132*
fax 202-767-0594

Mr. Manmohan S. Chawla
Mr. Richard Thomas
Naval Facilities Environmental
Service Center East
Washington Navy Yard
Washington, DC 20374
tel 202-433-8764
fax 202-433-8777

Mr. Joseph Kaminski, Code 41
Headquarters, Naval Facilities
Engineering Command
200 Stovall Street
Alexandria, VA 22332
tel 703-325-5104
fax 703-325-0183

Ms. Kathleen Kinsley
Code 71
Naval District of Washington
Washington Navy Yard Bldg 166
Washington, DC 20374
tel 202-433-7182

Mr. Abe Nashabe
Code ESC 423
Naval Facilities Environmental Service Center West
560 Center Drive
Port Hueneme, CA 93043-4328
tel 805-982-3016
fax 805-982-4832

Mr. Wayne Nishimoto
Insitu Pipe Coating Co.
4140 Trieste Drive
Carlsbad, CA 92008
tel 619-721-2577
fax 619-721-2578

Mr. Michael Putnam
Naval Command, Communications and Ocean Sciences Center
RDT&E Division, Code 521
49590 Lassing Road
San Diego, CA 92152
tel 619-553-2926
fax 619-553-1769

Mr. Steve Tjekas
Public Works Center, Code 490
Naval District of Washington
Washington Navy Yard Bldg 218
Washington, DC 20374
tel 202-685-8492
fax 202-685-8235

The individuals on the preceding two pages and the following individuals received a copy of the Technology Demonstration Plan:

Mr. Carl Adema
SERDP
901 N Stuart Street, Suite 303
Arlington, VA 22203
tel 703 696 2125
fax 703 696 2114

Ms. Jane Anderson
US Army Center for Public Works
ATTN: CECPW-ES
7701 Telegraph Road
Alexandria, VA 22315-3862
tel 703-806-5214

Mr. Dirk Bouma
2306 Dexter Avenue
Silver Spring, MD 20902
tel 301-417-6078

Mr. George Glavis
US Department of State
PO Box 5144
Falls Church, VA 22044
tel 703-875-5741

Mr. Michael Gustavson
Naval Sea Systems Command Detachment PERA-CV
1305 Ironsides
Bremerton, WA 98310-4924
tel 206 476 4260
fax 206 476 3078

Mr. Leonard A. Helt
Newport Chemical Activity
Mason & Hanger-Silas Mason Co., Inc.
P. O. Box 458
Newport, IN 47966
tel 317-245-2251

Mr. Les Keffer
Pollution Prevention Division AF/CEVV

Office of the Chief Engineer
1260 Air Force Pentagon
Washington, DC 20330
tel 703 697 2797 or 2928
fax 703 695 8943

Mr. Terry Knight
LANTDIV Code 18 (Environmental)
Naval Facilities Engineering Command
1510 Gilbert Street
Norfolk, VA 23511-2699
tel 804-322-4738
fax 804-322-4805

Mr. R. Lubbert, Head
Installation Restoration Branch CEMP-RA
US Army Corps of Engineers
20 Massachusetts Avenue NW
Washington, DC 20314-1000
tel 202 504 4950

Dr. Jeff Marqusee
ESTCP Program Manager
Room 3D768, The Pentagon
Washington, DC 20301
tel 703 614 3090
fax 703 693 2659

LT COL R. McMahon
Maintenance Policy Division AF/LGMM
1260 Air Force Pentagon
Washington, DC 20330
tel 703 697 6319

90 AMDS/SGPB
ATTN: TSGT Miller
6900 Alden Drive
F. E. Warren AFB
Cheyenne, WY 82005

CAPT Patrice Melancon
AFCEE/ERD
8001 Inner Circle Drive, Suite 2
Brooks AFB, TX 78235

tel 210 536 5208
fax 210 536 9026

Dr. Alanna Mitchell
Walcoff Associates
2001 N Beauregard Street
Alexandria, VA 22311
tel 703 578 8222
fax 703 578 5746

Mr. Steven Mori
American Pipelining Corporation
5780 Chesapeake Court, Suite #1
San Diego, CA 92123
tel 619-278-7991
fax 619-278-7993

COL D. Murphy, Director
Directorate of Housing AF/CEH
Office of the Chief Engineer
1260 Air Force Pentagon
Washington, DC 20330
tel 703 695 0236
fax 703 695 8943

Mr. Richard O'Donnell
US Army Environmental Center
ATTN: SFIM-AEC-ETD
Aberdeen Proving Ground, MD 21010-5401
tel 410 612 6850
fax 410 612 6836

Mr. Charles Racine
Center for Public Works
US Army Corps of Engineers
Fort Belvoir, VA 22060-5606

Mr. D. Olson, Head
Installation Restoration Branch N453
Crystal Plaza 5, Room 718
2211 Jefferson Davis Highway
Arlington, VA 22202
tel 703 602 2571



Appendix B

Data Archiving and Demonstration Plans

All data resulting from this demonstration is contained in this report or is incorporated by reference. The Technology Demonstration Plan may be obtained from Robert F. Brady or James D. Adkins at the address found in Appendix A.



Appendix C

Contractor's Production Reports

Eighteen pages follow.



INSITU PIPE COATING INC.

17 Sept

To: Dr. Robert Brady

Fr: Wayne Nishimoto

Ref: Anacostia demonstration

For your review and comments the following is the technical report as outlined in the DD Form 1423-1 included in the Contract.

3205 PRODUCTION AVE. • OCEANSIDE, CA 92054
(619) 721 - 2577 • FAX (619) 721 - 2578

OBJECTIVE:

Prove that the Naval Research Laboratory lining material can be applied by the "Air-Sand" method to drinking water piping at Navy shore facilities.

LOCATION:

Naval Station Anacostia

DATES:

July 1996

PERSONNEL INVOLVED:

Dr. Robert Brady, NRL
Dr. Jim Adkins, NRL
Wayne Nishimoto, IPC

REFERENCES:

- (a) Naval Research Laboratory Contract No. N00014-96-C-2007, P0001, A00001
- (b) Plumber's Pricing Manual published by Trade Service Corporation, 10996 Torreyana Road, San Diego, CA 92121. 800-854-1527

EQUIPMENT:

<u>Type</u>	<u>Size</u>
Compressor, Rotary Screw, Diesel	900 CFM
After cooler/dryer	1,350 CFM
Pre-cooler/Re-heater	1,600 CFM

GENERAL SCHEDULE:

In preparation for lining the piping system was divided into "run segments". All faucets and fixtures were then disconnected. A temporary transition was connected to the piping to accommodate the connection of air hoses. Air was then introduced into every inlet of the run segment to dry the interior surface of the the piping. After drying a measured amount of Garnet was introduced into each inlet to clean and establish an anchor tooth pattern on the interior pipe surface.

SAFETY :

All air hose and fittings were checked for integrity. Particular attention was given to the hose end fittings that were checked for any cracks and fitting slipping.

All air hoses connects larger than one inch was safety tied with a "whip-check". Cam arms were also safety wired in the lock position.

All air hoses were "traced" and identified on both ends to insure the correct hose is always turned on.

With all hoses connected to the piping system air pressure was increased in step increments with the hoses and piping system checked before each increasing step.

PROCESS:

See technical proposal and demonstration plan for process discription.

Problem: No mechanical drawings available to verify pipe routing

Resolution: All the piping was physically traced and proofed by sending low pressure air through the piping and verifying the routing by the air exhaust point(s).

Problem: Numerous deviations from normally accepted plumbing practices. These deviations included but not limited to the following:

- a. Galvanized steel pipe connected directly to copper pipe.
- b. Long lengths of deadend pipe connected to the piping system.
- c. Smaller pipe diameter pipe between larger diameter pipe in a single pipe run.

Resolution: All serious deviations were corrected prior to cleaning and lining so no hot work to correct the deviations would have to be performed by the building owner after lining was in place.

RECOMMENDATION:

To prevent any cross contamination of the potable water system a Back Flow Preventer should be installed where the water main enters the building.

Installed faucets, fixtures and drinking fountains not tested for lead leaching level should be replaced with mechanical plumbing devices that have been tested and shown to leach minimal amounts of lead into water.

Building Number 171 Ledgends Restaurant

Date: 12 July 1996

Pipe Segment Lined 171-1 Hot & Cold

Diameter 1/2" -- 2"

Base Material Copper

Location East side of building

Length 670'

ABRASIVE CLEANING

Abrasive Type Garnet

Size 16/80 Mesh

Manufacturer Emeral Crook

Lot/Batch Num N/A

Quantity 15 Pounds

Barton Mines

	Inlet	Outlet
Air Temperature	<u>120</u>	<u>120</u>
Pipe Profile	<u>No pits</u>	<u>No pits</u>
Anchor Tooth	<u>1.5</u>	<u>1.5</u>

Pneumatic Pressure Test Results (70 psi/5 min) (Pass/Fail): Pass

EPOXY COATING

1st Coat 2nd Coat 3rd Coat

Epoxy Resin (Part A)

Manufacturer

American Pipe Lining, Inc

NSF Certification

APL 2000

Lot Number

60196 Expiration Date 6-97

Curing Agent (Part B)

Manufacturer

Air Products

NSF Certification

APL 2000

Lot Number

IC15B12446 Expiration Date 6-97

Compressed Air

Inlet Temperature

120 120 120

Outlet Temperature

120 120 120

Oil content

Less Than .09 PPM

Water content

Run Time

Begin

17:30 09:30 14:00

End

18:15 10:15 15:15

Dry Film Thickness

Inlet

5 MILs 6 MILs 6 MILs

Outlet

6 MILs 6 MILs 7 MILs

INSPECTION

Visual Inspection

100% Coverage from all coats

Knife Peel Test

Bond Test

Thickness

5 6 6

PIPE SEGMENT ACCEPTED (Yes/No) YES.

REMARKS Cleaning and lining of the piping system was started from the

main feed shut-off valve located in the ceiling between the east
ladies/Mens bathrooms. This "run" segment ended in the ceiling

above the Grill in the kitchen. A one way check valve was installed immediately
down stream from the shut-off valve.

main feed shut-off valve located in the ceiling between the east
Ladies/Mens bathrooms. This "run" segment ended in the ceiling

above the Grill in the kitchen. A one way check valve was installed immediately
down stream from the shut-off valve.

PERSONNEL INVOLVED:

Dr. Robert Brady, NRL
Dr. Jim Adkins, NRL
Wayne Nishimoto, IPC

REFERENCES:

- (a) Naval Research Laboratory Contract No. N00014-96-C-2007, P0001, A00001
- (b) Plumber's Pricing Manual published by Trade Service Corporation, 10996 Torreyana Road, San Diego, CA 92121. 800-854-1527

Building Number 171 Leugenus Restaurant

Date: 17 July 1996

Pipe Segment Lined 171-2 Hot & Cold
Diameter 1/2" -- 2"
Location West side of building

Base Material Copper
Length 425'

ABRASIVE CLEANING

Abrasive Type Garnet
Lot/Batch Num N/A

Size 16/80 Mesh
Quantity 12 Pounds

Manufacturer Emeral Creek Barton Mines

	Inlet	Outlet
Air Temperature	<u>120</u>	<u>120</u>
Pipe Profile	<u>NO Pits</u>	<u>No Pits</u>
Anchor Tooth	<u>1.5</u>	<u>1.5</u>

Pneumatic Pressure Test Results (70 psi/5 min) (Pass/Fail): PASS

EPOXY COATING

Epoxy Resin (Part A)

	1st Coat	2nd Coat	3rd Coat
Manufacturer	<u>American Pipe Lining, Inc</u>		
NSF Certification	<u>APL 2000</u>		
Lot Number	<u>60196 Expiration Date 6-97</u>		

Curing Agent (Part B)

	1st Coat	2nd Coat	3rd Coat
Manufacturer	<u>- Air Products</u>		
NSF Certification	<u>APL 2000</u>		
Lot Number	<u>1C15B12446 Expiration Date 6-97</u>		

Compressed Air

	1st Coat	2nd Coat	3rd Coat
Inlet Temperature	<u>120</u>	<u>120</u>	<u>120</u>
Outlet Temperature	<u>120</u>	<u>120</u>	<u>120</u>
Oil content	<u>Less Than .09 PPM</u>		
Water content	<u></u>	<u></u>	<u></u>

Run Time

	1st Coat	2nd Coat	3rd Coat
Begin	<u>10:30</u>	<u>16:30</u>	<u>08:00</u>
End	<u>11:45</u>	<u>17:00</u>	<u>08:45</u>

Dry Film Thickness

	1st Coat	2nd Coat	3rd Coat
Inlet	<u>5 MILs</u>	<u>6 MILs</u>	<u>6 MILs</u>
Outlet	<u>6 MILs</u>	<u>6 MILs</u>	<u>6 MILs</u>

INSPECTION

Visual Inspection	<u>100% Coverage from all coats</u>		
Knife Peel Test	<u></u>	<u></u>	<u></u>
Bond Test	<u></u>	<u></u>	<u></u>
Thickness	<u>6</u>	<u>6</u>	<u>6</u>

PIPE SEGMENT ACCEPTED (Yes/No) Yes

REMARKS This run segment started from the west bathrooms and the west water heater. The "run" segment ended above the Grill in the kitchen.

Figure 1. EPOXY LINING PRODUCTION REPORT

Building Number 171 Ledgens Restaurant

Date: 16 July 1996

Pipe Segment Lined 171-3 Hot & Cold
 Diameter 1/2" -- 3/4"
 Location Center of Building

Base Material Copper
 Length 90'

ABRASIVE CLEANING

Abrasive Type Garnet
 Lot/Batch Num N/A

Size 16/80 Mesh
 Quantity 4 Pounds

Manufacturer Emcral Creek
Barton Mines

	Inlet	Outlet
Air Temperature	<u>120</u>	<u>120</u>
Pipe Profile	<u>No Pits</u>	<u>No Pits</u>
Anchor Tooth	<u>1.3</u>	<u>1.5</u>

Pneumatic Pressure Test Results (70 psi/5 min) (Pass/Fail): PASS

EPOXY COATING

	1st Coat	2nd Coat	3rd Coat
Epoxy Resin (Part A)			
Manufacturer	<u>American Pipe Lining, Inc.</u>		
NSF Certification	<u>API 2000</u>		
Lot Number	<u>60196 Expiration Date 6-97</u>		

	1st Coat	2nd Coat	3rd Coat
Curing Agent (Part B)			
Manufacturer	<u>Air Products</u>		
NSF Certification	<u>APL 2000</u>		
Lot Number	<u>LC15B12446 Expiration Date 6-97</u>		

	1st Coat	2nd Coat	3rd Coat
Compressed Air			
Inlet Temperature	<u>120</u>	<u>120</u>	<u>120</u>
Outlet Temperature	<u>120</u>	<u>120</u>	<u>120</u>
Oil content	<u>Less Than .09 PPM</u>		
Water content			

	1st Coat	2nd Coat	3rd Coat
Run Time			
Begin	<u>13:00</u>	<u>18:00</u>	<u>08:30</u>
End	<u>13:30</u>	<u>18:30</u>	<u>09:00</u>

	1st Coat	2nd Coat	3rd Coat
Dry Film Thickness			
Inlet	<u>6 Mils</u>	<u>6 Mils</u>	<u>6 Mils</u>
Outlet	<u>6 Mils</u>	<u>6 Mils</u>	<u>6 Mils</u>

INSPECTION

Visual Inspection	<u>100% Coverage from all coats</u>		
Knife Peel Test			
Bond Test			
Thickness	<u>6</u>	<u>6</u>	<u>6</u>

PIPE SEGMENT ACCEPTED (Yes/No) YES

REMARKS This run segment included all the piping in the automatic dish washer/garbage disposal section of the restaurant. The "run" segment ended at the point where the piping comes up from under the floor slab.

11/10/17

LEGGERS RESTAURANT

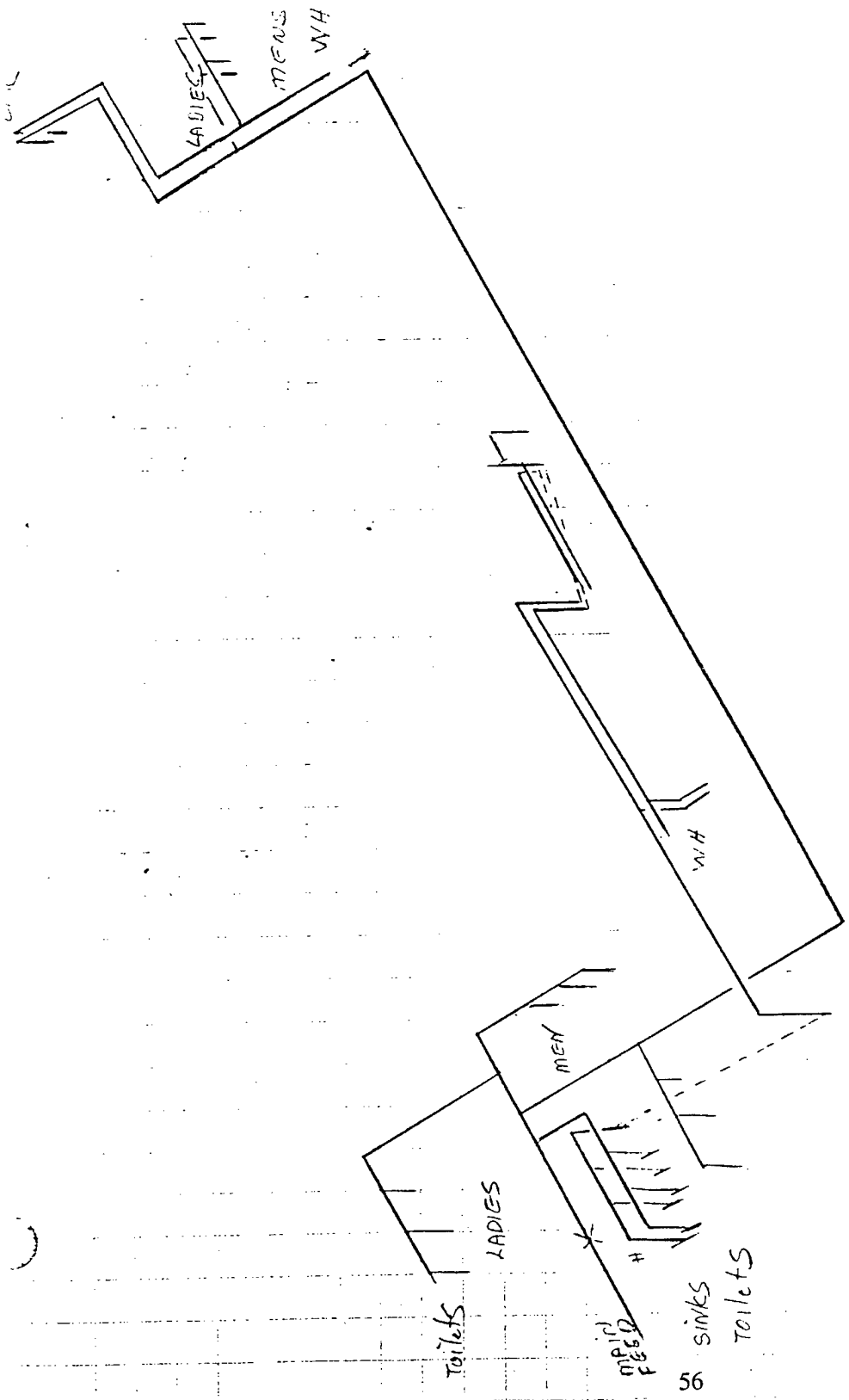

Figure 1. EPOXY LINING PRODUCTION REPORT

Building Number 2 and 87 Detention Facility

Date: 18 July 1996

Pipe Segment Lined 2/87 - 1

Diameter 1/2" - 1 1/4"

Location Building 2

Base Material Copper

Length 350'

ABRASIVE CLEANING

Abrasive Type Garnet

Lot/Batch Num N/A

Size 16/80 Mesh

Quantity 15 Pounds

Manufacturer Emeral Creek

Barton Mines

	Inlet	Outlet
Air Temperature	<u>120</u>	<u>120</u>
Pipe Profile	<u>No Pits</u>	<u>No Pits</u>
Anchor Tooth	<u>1.5</u>	<u>1.5</u>

Pneumatic Pressure Test Results (70 psi/5 min) (Pass/Fail): PASS

EPOXY COATING

Epoxy Resin (Part A)

Manufacturer

NSF Certification

Lot Number

1st Coat

2nd Coat

3rd Coat

American Pipe Lining Inc

APL 2000

6/19/96 Expiration Date 6-97

Curing Agent (Part B)

Manufacturer

NSF Certification

Lot Number

Air Products

APL 2000

LC15BJ2446 Expiration Date 6-97

Compressed Air

Inlet Temperature

Outlet Temperature

Oil content

Water content

120

120

120

120

120

120

Less Than .09 PPM

Run Time

Begin

End

16:30

08:00

14:30

17:45

09:15

15:45

Dry Film Thickness

Inlet

Outlet

6 Mils

6 Mils

6 Mils

7 Mils

6 Mils

6 Mils

INSPECTION

Visual Inspection

Knife Peel Test

Bond Test

Thickness

100% Coverage from all coats

6

6

6

PIPE SEGMENT ACCEPTED (Yes/No) YES

REMARKS Building 2 and building 87 are joined immediately east of the Mechanical room, located in Bldg.-87 by a short hallway. A temporary water system was constructed to accommodate the tenants while the piping system was being cleaned and lined. Showers, washer, wash basins and toilets were connected to the temporary water system. The piping was divided into two run segments. The dividing point was in the ceiling above the hallway north of the mechanical room.

Figure 1. EPOXY LINING PRODUCTION REPORT

Building Number 2 and 87 Detention Facility

Date: 20 July 1996

Pipe Segment Lined 2/87 - 2

Diameter 1/2" - 2"

Location Building 87

Base Material Copper

Length 615'

ABRASIVE CLEANING

Abrasive Type Garnet

Size 16/80 Mesh

Manufacturer Emeral Creek

Lot/Batch Num N/A

Quantity 15 Pounds

Barton Mines

	Inlet	Outlet
Air Temperature	<u>120</u>	<u>120</u>
Pipe Profile	<u>No Pits</u>	<u>No Pits</u>
Anchor Tooth	<u>1.5</u>	<u>1.5</u>

Pneumatic Pressure Test Results (70 psi/5 min) (Pass/Fail): PASS

EPOXY COATING

Epoxy Resin (Part A)

Manufacturer

NSF Certification

Lot Number

1st Coat 2nd Coat 3rd Coat

American Pipe Lining, Inc

APL 2000

60196 Expiration Date 6-97

Curing Agent (Part B)

Manufacturer

NSF Certification

Lot Number

Air Products

APL 2000

LC15B12446 Expiration Date 6-97

Compressed Air

Inlet Temperature

Outlet Temperature

Oil content

Water content

120

120

120

120

120

120

Less Than .09 PPM

Run Time

Begin

End

15:00

08:30

15:00

16:30

09:45

16:30

Dry Film Thickness

Inlet

Outlet

5 Mills

6 Mills

6 Mills

6 Mills

6 Mills

6 Mills

INSPECTION

Visual Inspection

Knife Peel Test

Bond Test

Thickness

100% Coverage from all coats

6

6

6

PIPE SEGMENT ACCEPTED (Yes/No) YES.

REMARKS Building 2 and building 87 are joined immediately east of the Mechanical room, located in Bldg. 87 by a short hallway. A temporary water system was constructed to accommodate the tenants while the piping system was being cleaned and lined. Showers, washer, wash basins and toilets were connected to the temporary water system. The piping system was divided into two run segments. The dividing point was in the ceiling above the hallway north of the mechanical room.

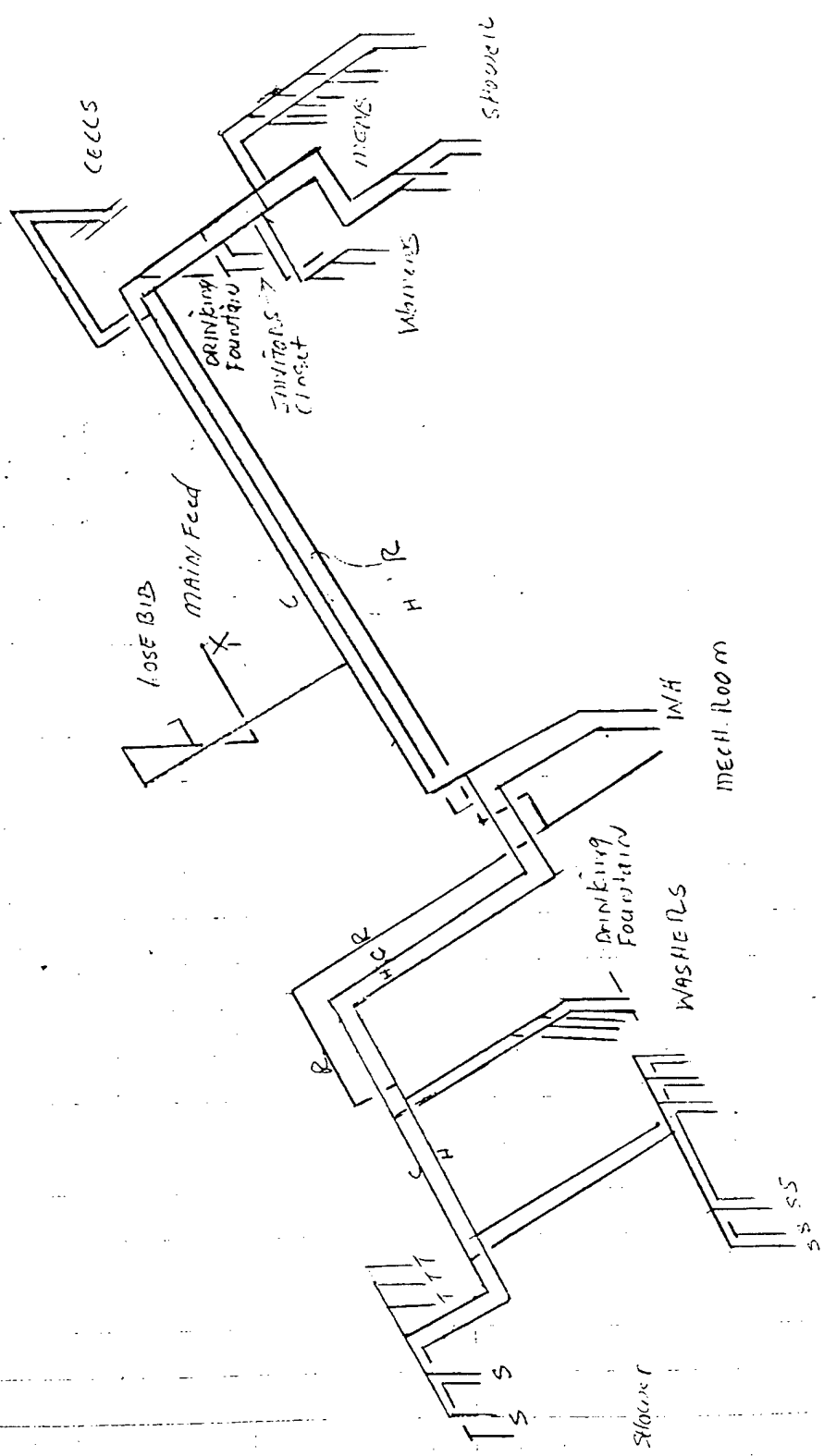

Figure 1. EPOXY LINING PRODUCTION REPORT

Building Number 93 B00 Date: 23 July 1996
 Pipe Segment Lined 93-1
 Diameter 1/2" -- 2" Base Material Copper
 Location East End of Bldg. 1st and 2nd floor Length 310'

ABRASIVE CLEANING

Abrasive Type Garnet Size 35/60 Manufacturer Emerald Creek Barton Mines
 Lot/Batch Num N/A Quantity 20 Pounds

	Inlet	Outlet
Air Temperature	120	120
Pipe Profile	No Pits	No Pits
Anchor Tooth	1.5	1.5

Pneumatic Pressure Test Results (70 psi/5 min) (Pass/Fail): PASS

	1st Coat	2nd Coat	3rd Coat
EPOXY COATING			
Epoxy Resin (Part A)	American Pipe Lining, Inc.		
Manufacturer	APL 2000		
NSF Certification	60196		
Lot Number	Expiration Date 6-97		
Curing Agent (Part B)	Air Products		
Manufacturer	APL 2000		
NSF Certification	LC15B12446		
Lot Number	Expiration Date 6-97		
Compressed Air			
Inlet Temperature	120	120	120
Outlet Temperature	120	120	120
Oil content	Less Than .09 PPM		
Water content			
Run Time			
Begin	16:00	08:00	14:30
End	18:30	09:45	16:45
Dry Film Thickness			
Inlet	5 Mils	5 Mils	6 Mils
Outlet	5 Mils	6 Mils	7 Mils

INSPECTION

Visual Inspection	100% Coverage from all coats		
Knife Peel Test			
Bond Test			
Thickness	5	6	6

PIPE SEGMENT ACCEPTED (Yes/No) YES

REMARKS A temporary hot and cold water system was constructed for all the rooms, kitchen and clothes washer.

Treatment segment 1 was from the mechanical room east to the end of the building.

Building Number 93 B0Q

Date: 26 July 1996

Pipe Segment Lined 93-2

Diameter 1/2" -- 2 1/2"

Location Mid-Section 1st and 2nd Floor

Base Material Copper

Length 729'

ABRASIVE CLEANING

Abrasive Type Garnet

Lot/Batch Num N/A

Size 35/60 Mesh

Quantity 20 Pounds

Manufacturer Emeral Creek

Barton Mines

	Inlet	Outlet
Air Temperature	<u>120</u>	<u>120</u>
Pipe Profile	<u>No Pits</u>	<u>No Pits</u>
Anchor Tooth	<u>1.5</u>	<u>1.5</u>

Pneumatic Pressure Test Results (70 psi/5 min) (Pass/Fail): PASS

EPOXY COATING

Epoxy Resin (Part A)

Manufacturer

NSF Certification

Lot Number

1st Coat 2nd Coat 3rd Coat

American Pipe Lining, Inc

APL 2000

60196 Expiration Date 6-97

Curing Agent (Part B)

Manufacturer

NSF Certification

Lot Number

Air Products

APL 2000

LC15B12446 Expiration Date 6-97

Compressed Air

Inlet Temperature

Outlet Temperature

Oil content

Water content

120

120

120

120

120

120

less than .09 PPM

Run Time

Begin

End

18:00

08:00

15:30

19:30

09:30

16:45

Dry Film Thickness

Inlet

Outlet

5 Mils

5 Mils

6 Mils

6 Mils

6 Mils

7 Mils

INSPECTION

Visual Inspection

Knife Peel Test

Bond Test

Thickness

100% Coverage from all coats

6

6

6

PIPE SEGMENT ACCEPTED (Yes/No) YES

REMARKS Treatment segment 2 was from the mechanical room, including the mechanical room, west half the distance to the end of the building. The recirculation pipe was not cut dividing the recirculation in three segments. The recirculation pipe was done in two segments.

Figure 1. EPOXY LINING PRODUCTION REPORT

Building Number 93 B00 Date: 29 July 1996
 Pipe Segment Lined 93-3
 Diameter 1/2" - 2" Base Material Copper
 Location West end of Bldg. 1st and 2nd floor Length 486'

ABRASIVE CLEANING

Abrasive Type Garnet Size 35/60 Manufacturer Emeral Creek
 Lot/Batch Num N/A Quantity 20 Pounds Barton Mines

	Inlet	Outlet
Air Temperature	120	120
Pipe Profile	No Pits	No Pits
Anchor Tooth	1.5	1.5

Pneumatic Pressure Test Results (70 psi/5 min) (Pass/Fail): PASS

EPOXY COATING

	1st Coat	2nd Coat	3rd Coat
Epoxy Resin (Part A)			
Manufacturer	<u>American Pipe Lining Inc</u>		
NSF Certification	<u>APL 2000</u>		
Lot Number	<u>60196</u>	<u>Expiration Date 6-97</u>	
Curing Agent (Part B)			
Manufacturer	<u>Air Products</u>		
NSF Certification	<u>APL 2000</u>		
Lot Number	<u>1015812446</u>	<u>Expiration Date 6-97</u>	
Compressed Air			
Inlet Temperature	<u>120</u>	<u>120</u>	<u>120</u>
Outlet Temperature	<u>120</u>	<u>120</u>	<u>120</u>
Oil content	<u>Loss Than .09 PPM</u>		
Water content			
Run Time			
Begin	<u>15:00</u>	<u>09:00</u>	<u>15:00</u>
End	<u>16:45</u>	<u>10:30</u>	<u>16:30</u>
Dry Film Thickness			
Inlet	<u>5 MILs</u>	<u>6 MILs</u>	<u>6 MILs</u>
Outlet	<u>6 MILs</u>	<u>6 MILs</u>	<u>6 MILs</u>

INSPECTION

Visual Inspection	<u>100% Coverage from all coats</u>		
Knife Peel Test			
Bond Test			
Thickness	<u>6</u>	<u>6</u>	<u>6</u>

PIPE SEGMENT ACCEPTED (Yes/No) YES

REMARKS Treatment segment 3 was from the end of segment 2, west, to the end of the building. The second segment of the recirculation piping was included in this treatment segment.

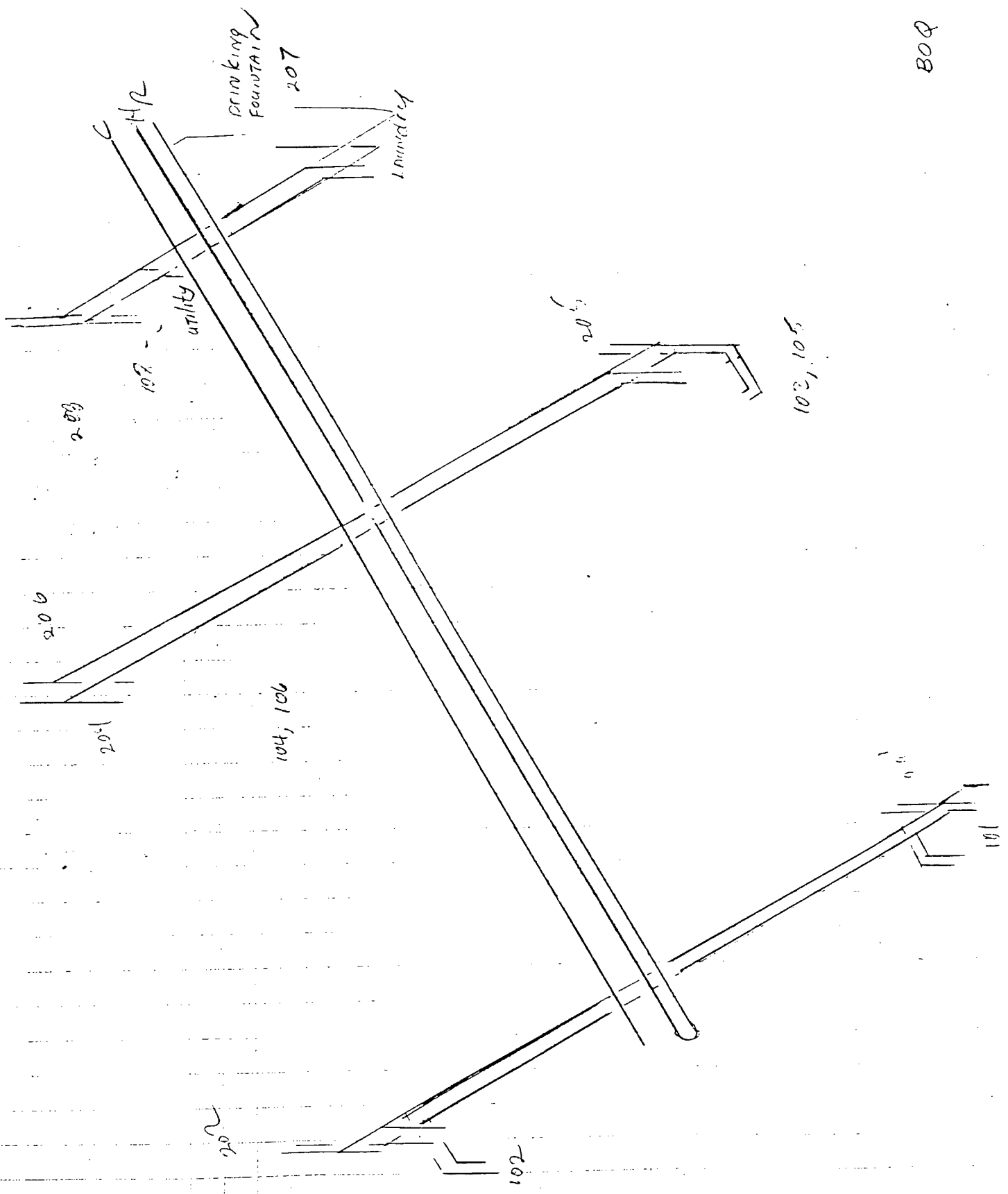

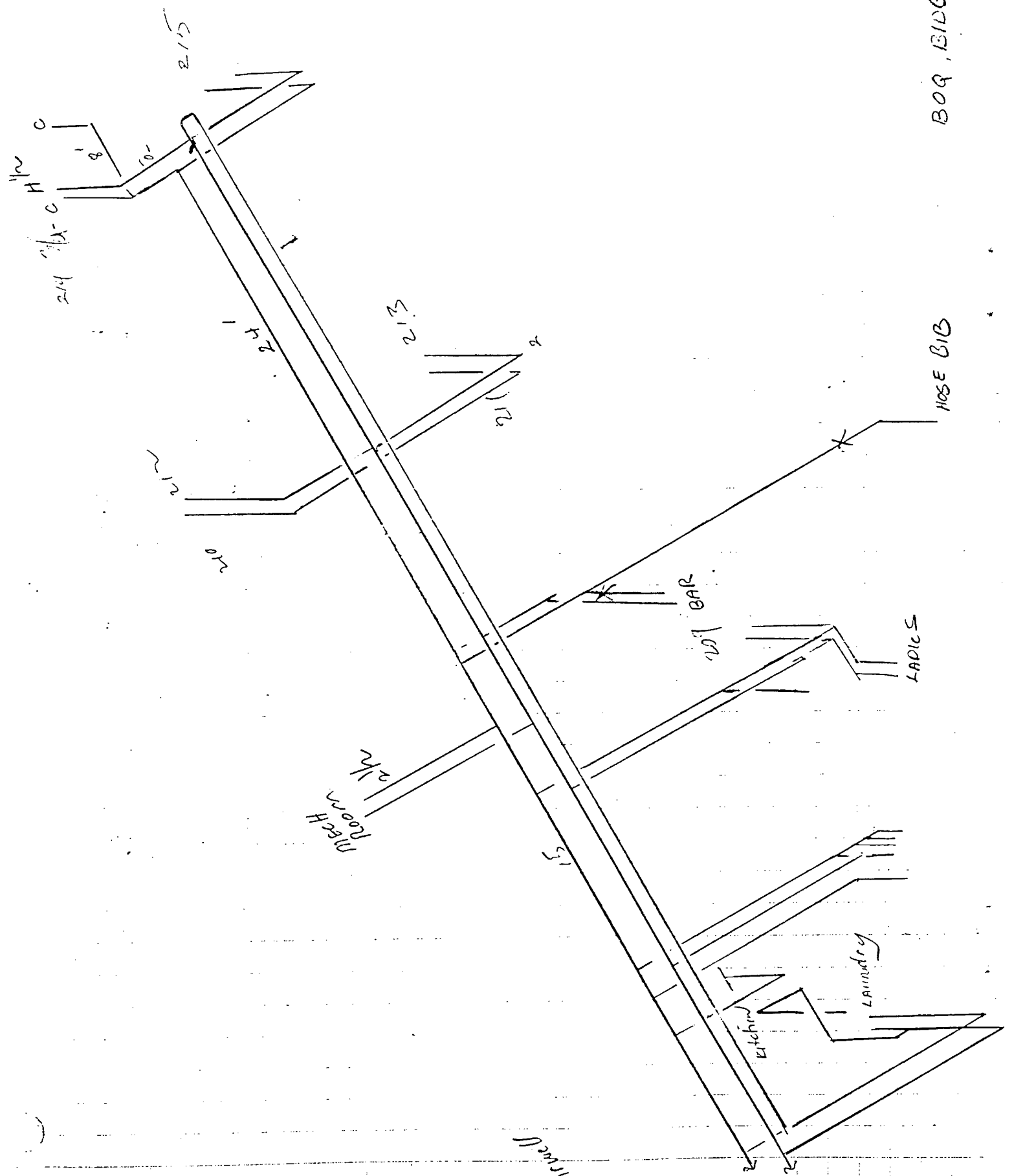

STAINLESS

Psych Room
Bldg 93

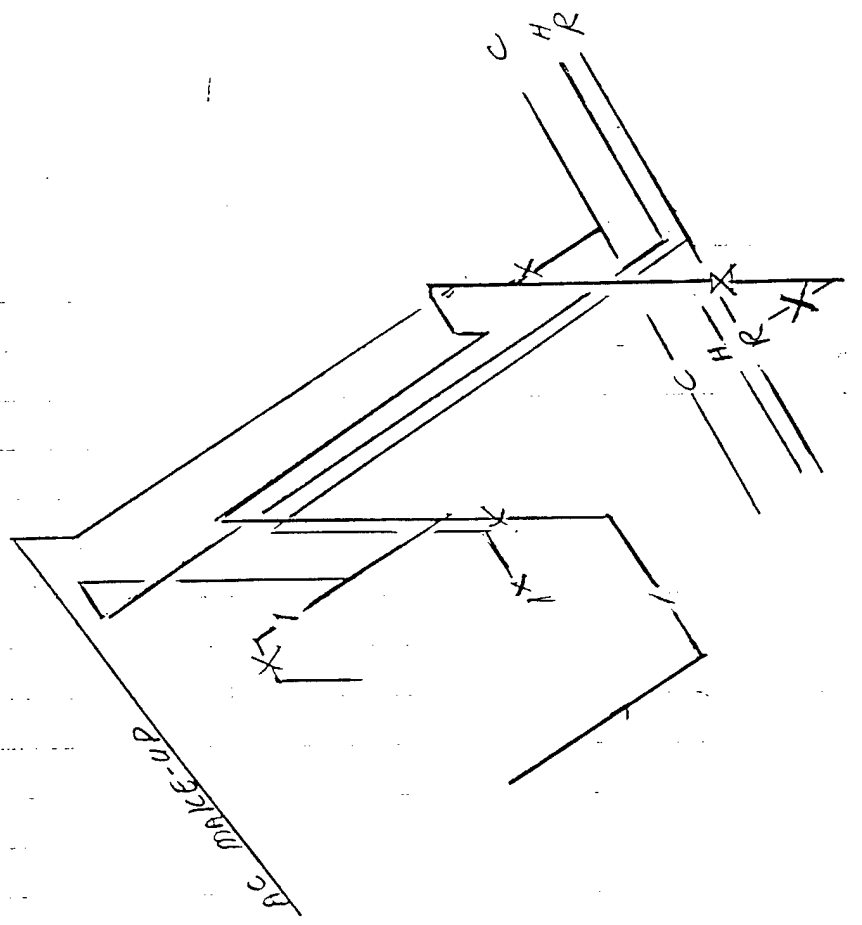



Appendix D

Contracting Guidance

1. Statement of Work

A. Introduction

The Naval Research Laboratory (NRL) has developed an interior lining used to repair copper-nickel pipe aboard aircraft carriers. This lining was developed specifically for use with the "Air-Sand" application process, and performs properly only when applied in this manner. Since 1988, the piping systems aboard 12 aircraft carriers have been successfully lined. This technology has also been successfully demonstrated to obviate lead problems in shore facilities potable water systems (Washington Navy Yard, Washington D. C., 1996).

B. Scope of Work

The drinking water system is defined as all hot and cold water piping between the place(s) where the water main(s) enter the building to the valve fixture on every tap, shower, sink, tub, urinal, and toilet.

The contractor shall perform the work in the following buildings where the pipes are to be lined.

BASE REQUIREMENT (CLIN 0001)

- (LIST BUILDINGS)

OPTION (if exercised) (CLIN 0002)

- (LIST BUILDINGS)

C. Specific Contract Requirements

1. The contractor shall replace any pipe found to be defective (less than 50% of original wall thickness prior to lining. The contractor shall also make all necessary connections mechanical to avoid hot work and provide dielectric unions to prevent bimetallic corrosion on the completed piping system.

2. The contractor shall, where specified, provide temporary water service to fixtures using NSF/ANSI certified materials as necessary.

3. The contractor shall use an National Sanitation Foundation (NSF), Ann Arbor, Michigan approved NRL Series 4 epoxy lining to perform this project. Certification that the lining has been tested and found to be suitable under NSF/ANSI Standard 61, "Drinking Water System Components - Health Effects" must be provided prior to commencing work. This requirement is in accordance with Environmental Protection Agency regulations governing materials which come into contact with drinking water.

4. The contractor shall use the "Air-Sand" method to perform the work which includes cleaning and preparing the inside of the water pipe's surface prior to lining.

5. The contractor shall not line internal surfaces of valves, hot water heaters, drinking water fountains, drainage, and heating systems.

6. The application of the epoxy lining must be uniform and defect - free. The contractor shall reassemble the water piping system, make it watertight, and return the piping to its original configuration (unless otherwise specified). The contractor shall restore the work site to its original appearance, unless otherwise specified.

7. The contractor shall flush the drinking water system to remove impurities after the lining is installed and immediately prior to putting the system back in service. The water quality shall be tested and found to be acceptable prior to use.

8. The contractor shall furnish all materials and equipment necessary to accomplish the work. All applicable federal and local regulations regarding environmental protection and worker safety must be observed. The contractor shall dispose of all waste materials, including used abrasives, in accordance with federal and local regulations.

9. (BASE REQUIREMENT) The contractor shall deliver the Technical Report in accordance with the Contract Data Requirements List (CDRL), DD Form 1423.

(OPTION, if exercised) The contractor shall deliver the Technical Report in accordance with the Contract Data Requirements List (CDRL), DD Form 1423.

2. Information Required to Evaluate Proposals

A. Each offeror shall submit a technical proposal. To assist in the evaluation of the technical proposals received, each offeror shall provide a technical proposal that provides the information in subsection 2B (below) presented in the same order and format as requested below or suitably referenced to paragraphs/pages of the offeror's proposal.

Further, the technical proposal must demonstrate an understanding of all requirements covered in the Statement of Work (SOW) contained in the Request for Proposal (RFP) and address the technical evaluation factors for award described in Section 4 below. The proposal must be sufficiently detailed and complete to demonstrate an understanding of and an ability to comply with the requirements of the RFP. General statements that the offeror can or will comply with the requirements, that standard procedures will be used, that well-known techniques will be used, or paraphrases of the RFP's SOW in whole or in part *will not* constitute compliance with these requirements concerning the content of the technical proposal. Failure to conform to the requirements of the RFP may form the basis for rejection of the proposal.

B. The following items are required to be included in the offeror response to this solicitation:

1. A brief history of the offeror's firm.
2. A full description of the offeror's production equipment and facilities that would support the proposed work.
3. A listing of recent Department of Defense, other national, state or local government, or commercial contracts under which the offeror has performed and/or furnished identical or similar services, accompanied by names and telephone numbers of customers and technical personnel involved in each contract.
4. A statement of the offeror's percentage of sales with the federal government and its percentage of sales with the commercial sector during the preceding 12 months.
5. A specific statement whether or not the technical proposal concurs with the SOW, and a full description of any and all exceptions the offeror takes with the SOW in the technical proposal.

3. Site Visit

A. A site visit shall be scheduled with (*insert name of contacting activity*) on (*insert date and time*). Those offerors attending will be transported to the buildings where work will be actually performed.

B. *(if needed)* The site(s) are situated within secured facilities, and offerors shall be required to show identification, sign in, and shall be escorted during the site visit.

C. Please inform *(insert name of contracting officer)* before *(insert time 72 hours before site visit)* that you wish to take part in the site visit.

D. Offerors are urged to schedule an inspection of the site where services are to be performed and to satisfy themselves regarding all general and local conditions that may affect the cost of contract performance, to the extent that the information is reasonable obtainable. In no event shall failure to inspect the site(s) constitute grounds for a claim after the contract is awarded.

4. Evaluation Factors for Award

A. Technical Evaluation. The Statement of Work (SOW) and the Contract Data Requirements List (CDRL) are mandatory. In order for a proposal to receive a rating of "technically acceptable" it must demonstrate the intent to meet all specifications in the SOW on or before the required delivery date.

B. Basis for Award. Award of the contract will be made to the lowest priced, responsible offeror whose technical proposal is determined to be "technically acceptable" in accordance with paragraph 4A above.

5. Contract Data Requirements List (CDRL)

A technical report must be delivered to the contracting officer's technical representative not later than 30 days after completion of the work. The following areas must be documented and addressed in the Technical Report:

1. Types and size of equipment (i.e., compressor) utilized during work performed.
2. Material and procedures utilized to clean and flush piping.
3. Safety precautions used during the work performed, including those necessitated by the use of compressed air equipment.
4. Method of disposal of waste blast grit.
5. Description of the process, how it was performed, problems encountered and methods used to resolve them, outcome of the work.
6. Documentation from the National Sanitation Foundation stating that the coating to be used has been tested and approved by NSF for contact with domestic hot and cold drinking water. This documentation must include the date certification was granted, the product name and number of the coating certified, and the name and location of the plant certified to make the coating.

7. Any other pertinent information regarding the performance of the work.

6. Government Furnished Property

No material, labor, or facilities will be furnished by the Government unless provided or in this solicitation.

7. Inquiries Concerning this Request for Proposals

Any questions concerning this Request for Proposals must be submitted in writing to the Contracting Officer (*insert name and contact information*) no less than fifteen days before the closing date. The Government will not consider questions received after this date. Offerors are cautioned against directing any questions concerning this Request for Proposals to anyone other than the Contracting Officer.



Appendix E

Material Safety Data Sheets for the NRL Series 4 Lining

Eleven pages follow.

MANUFACTURER'S NAME: LASTING PAINT, INC.
STREET ADDRESS : 200 S. FRANKLINTOWN ROAD
CITY, STATE & ZIP : BALTIMORE, MD 21223
EMERGENCY PHONE # : (301) 947-6306
INFORMATION PHONE #: (301) 947-6300
DATE WRITTEN: 05/06/89

DATE ISSUED: 05/19/89

SECTION I - PRODUCT IDENTIFICATION

PRODUCT NUMBER : FS29-990 *NRL-4A*
PRODUCT NAME : XX EPOXY PIPE CTG (A)
PRODUCT CLASS : TWO COMPONENT EPOXY

SECTION II - HAZARDOUS INGREDIENTS

INGREDIENT	% WCHT TLV..... PPM VAPOR..... MG/M PRESS LEL
------------	--------	--------------------	---------------------------------

LEL expressed in percent; Vapor expressed in mmHg

SECTION III - PHYSICAL DATA

BOILING RANGE: 500.00 to 500.00 deg. F. % VOLATILE VOLUME: .20%

VAPOR DENSITY: HEAVIER LIGHTER THAN AIR
EVAPORATION RATE: FASTER SLOWER THAN ETHER
WT/GAL: 10.79 lbs.

SECTION IV - FIRE AND EXPLOSION HAZARD DATA

FLAMMABILITY CLASSIFICATION:

OSHA: COMBUSTIBLE LIQUID -CLASS IIIIB FLASH POINT: 480.00 deg. F.
(DOT: NOT REGULATED)

EXTINGUISHING MEDIA:

FOAM CO2 DRY CHEMICAL WATER FOG
USE ANY CLASS B APPROVED FIRE EXTINGUISHER

UNUSUAL FIRE AND EXPLOSION HAZARD:

KEEP CONTAINERS TIGHTLY CLOSED. ISOLATE FROM HEAT, ELECTRICAL EQUIPMENT, SPARKS AND OPEN FLAME. CLOSED CONTAINERS MAY EXPLODE WHEN EXPOSED TO EXTREME HEAT. APPLICATION TO HOT SURFACES REQUIRES SPECIAL PRECAUTIONS.

SPECIAL FIRE FIGHTING PROCEDURES

WATER SPRAY MAY BE INEFFECTIVE IF WATER IS USED. FOG NOZZLES ARE PREFERABLE. WATER MAY BE USED TO COOL CONTAINERS TO PREVENT PRESSURE BUILD-UP AND EXPLOSION. USE FULL PROTECTIVE EQUIPMENT INCLUDING SELF-CONTAINED BREATHING APPARATUS FOR PROTECTION

SECTION V - HEALTH HAZARDS

EFFECTS OF OVER EXPOSURE:

ORAL: TOXIC BY INGESTION. DERMAL: HARMFUL IF ABSORBED THROUGH THE SKIN. SENSITIZATION: MAY CAUSE ALLERGIC SKIN REACTION AND SENSITIZATION. INHALATION: HARMFUL IF INHALED. OVEREXPOSURE EFFECTS: HUMAN LIVER TOXIN. FEVER, CHILLS, ANOREXIA AND VOMITING. TOXIC HEPATITIS, JAUNDICE, HEPATOTOXIC EFFECTS. CARCINOGENIC IN LABORATORY TEST ANIMALS. PRODUCES ANEMIA AND LIVER, THYROID AND KIDNEY TOXICITY IN LABORATORY TEST ANIMALS.

MEDICAL CONDITIONS PRONE TO AGGRAVATION:

ALLERGY, ECZEMA OR SKIN CONDITIONS.

PRIMARY ROUTE OF ENTRY:

DERMAL INHALATION INGESTION

EMERGENCY AND FIRST AID PROCEDURES:

EYES: IMMEDIATELY FLUSH EYES WITH WATER FOR AT LEAST 15 MINUTES AND CALL PHYSICIAN. SKIN: PROMPTLY WASH THOROUGHLY WITH MILD SOAP AND WATER. INGESTION: IF CONSCIOUS, GIVE LARGE QUANTITIES OF WATER. INDUCE VOMITING. CALL PHYSICIAN. INHALATION: REMOVE TO FRESH AIR. GIVE OXYGEN IF BREATHING IS DIFFICULT. OTHER PROCEDURES: PROMPTLY REMOVE WET CONTAMINATED NON-IMPERVIOUS CLOTHING AND WASH BEFORE REUSE. DESTROY CONTAMINATED LEATHER AND ABSORBENT SHOES.

SECTION VI - REACTIVITY DATA

STABILITY UNSTABLE STABLE

HAZARDOUS POLYMERIZATION MAY OCCUR WILL NOT OCCUR

HAZARDOUS DECOMPOSITION PRODUCTS:

CARBON MONOXIDE, CARBON DIOXIDE, ALDEHYDES, NITROGEN OXIDES.

CONDITIONS TO AVOID:

AVOID HEAT AND OPEN FLAME.

INCOMPATIBILITY (MATERIALS TO AVOID):

STRONG OXIDIZERS AND ACIDS.

SECTION VII - SPILL OR LEAK PROCEDURES

STEPS TO BE TAKEN IN CASE MATERIAL IS RELEASED OR SPILLED

AVOID ALL PERSONAL CONTACT, TAKE UP WITH ABSORBENT MATERIAL. SHOVEL INTO CLOSABLE CONTAINERS. FLUSH CONTAMINATED AREA WITH WATER.

WASTE DISPOSAL METHOD:

DISPOSE IN ACCORDANCE WITH FEDERAL, STATE AND LO-

(continue on page 3)

SECTION VII - SPILL OR LEAK PROCEDURES continued

CAL REGULATIONS.

SECTION VIII - SAFE HANDLING AND USE INFORMATION

RESPIRATORY PROTECTION:

WITH RESTRICTED VENTILATION, USE ORGANIC CHEMICAL CARTRIDGE RESPIRATOR.

VENTILATION:

GOOD GENERAL MECHANICAL VENTILATION AND LOCAL EXHAUST.

PROTECTIVE GLOVES:

WEAR IMPERVIOUS GLOVES.

EYE PROTECTION:

WEAR SPLASH PROOF CHEMICAL GOGGLES.

OTHER PROTECTIVE EQUIPMENT:

WEAR APPROPRIATE EQUIPMENT TO PREVENT CONTACT WITH EYES AND SKIN AND INHALATION OF VAPORS OR MIST.

HYGIENIC PRACTICES:

WASH THOROUGHLY AFTER HANDLING.

SECTION IX - SPECIAL PRECAUTIONS

PRECAUTIONS FOR HANDLING AND STORAGE:

WARNING! HARMFUL IF SWALLOWED, INHALED OR ABSORBED THROUGH SKIN. MAY CAUSE IRRITATION AND SENSITIZATION. CONTAINS 101-77-9; 4,4'-METHYLENE DIANILINE, A LIVER TOXIN. DO NOT GET IN EYES, ON SKIN OR CLOTHING OR BREATHE VAPOR OR SPRAY MIST.

OTHER PRECAUTIONS:

ATTENTION! THIS MATERIAL CONTAINS A TOXIC CHEMICAL THAT APPEARS ON THE SARA TITLE III LIST. CONTAINS 36% 101-77-9; 4,4'-METHYLENE DIANILINE WHICH MUST BE ANNUALLY REPORTED UNDER SEC. 313 (40 CFR 372).

HMTS

HEALTH	4
ENVIRONMENT	3
REACT	0
EQUIP	0

MATERIAL SAFETY DATA SHEET

 SECTION 1 - MATERIAL IDENTIFICATION

PRODUCT NAME ANCAMIDEX 350A CURING AGENT
 *ANCAMIDE is a registered trademark of Air
 Products and Chemicals, Inc

PRODUCT CODE H350AU

MSDS REVISION NUMBER 5166 -04

MANUFACTURER Pacific Anchor Chemical
 Air Products and Chemicals, Inc
 7201 Hamilton Boulevard, Allentown, PA
 18195-1501

TELEPHONE NUMBER 800-345-3148

EMERGENCY TELEPHONE NUMBER(S)
 800-523-9374 (Continental U.S.)
 215-481-7711 (Outside Continental U.S.)
 800-322-9092 (Pennsylvania only)

DATE PREPARED MAY 1993

REVISION NOTES Updated Composition Information

C.A.S. CHEMICAL NAME Mixture
 SYNONYMS None
 CHEMICAL FAMILY Polyamide
 EMPIRICAL FORMULA Mixture
 INTENDED USE Epoxy Curing Agent

 SECTION 2 - INGREDIENTS

%	CAS Number and Chemical Name
<5	112-24-3 TRIETHYLENETETRAMINE
>95	68082-29-1 DIMER/TOFA, REACTION PRODUCTS WITH TETA

OSHA (ACGIH) EXPOSURE LIMITS						
CAS#	TWA		STEL		CEILING	
	ppm	mg/m3	ppm	mg/m3	ppm	mg/m3
112-24-3	N/E (N/E)	N/E (N/E)	N/E (N/E)	N/E (N/E)	N/E (N/E)	N/E (N/E)
68082-29-1	N/E (N/E)	N/E (N/E)	N/E (N/E)	N/E (N/E)	N/E (N/E)	N/E (N/E)

N/E = Not Established. All values in () are U.S. ACGIH (American Conf. of Gov. Indust. Hygienists) - TLV; All others are OSHA - PEL.

SECTION 3 - HEALTH HAZARDS

EMERGENCY OVERVIEW

HMS HEALTH RATING 2 FLAMMABILITY 1 REACTIVITY 0

Mobile liquid, Amber, Ammoniacal.

Moderate eye irritant. Moderate skin irritant. May cause skin sensitization.

Ignition will give rise to a Class B fire. In case of fire use:

Water Spray, Carbon Dioxide (CO2), Dry Chemical, Alcohol Foam.

ROUTES OF EXPOSURE

- Ingestion
- Skin Absorption
- Inhalation

EXPOSURE STANDARDS

No standards established for the product.

HEALTH HAZARDS

Moderate eye irritant. Moderate skin irritant. May cause skin sensitization.

TARGET ORGANS

Eye; Skin.

SIGNS AND SYMPTOMS OF EXPOSURE (Acute effects)

Contact with eyes causes irritation, redness and discomfort which is transient.

Contact with skin causes irritation, redness and discomfort which is transient.

Inhalation of vapors may cause irritation in the respiratory tract.

Ingestion may cause nausea unless treated promptly.

SIGNS AND SYMPTOMS OF EXPOSURE (Possible Longer Term Effects)

Repeated and/or prolonged exposure to low concentrations of vapor may cause: sore throat, eye irritation, nausea, headache.

Repeated and/or prolonged exposures may result in: adverse skin effects (such as defatting, rash, irritation or corrosion); adverse eye effects (such as conjunctivitis or corneal damage).

Repeated and/or prolonged contact with the skin may cause allergic reaction/sensitization.

MEDICAL CONDITIONS GENERALLY AGGRAVATED BY EXPOSURE

Asthma, Chronic respiratory disease (e.g. Bronchitis, Emphysema)

IRRITATION EFFECTS DATA

No irritation data are known for this product.

ACUTE TOXICITY EFFECTS DATA

Oral LD50 (rat): >2000 mg/kg (estimate)
Dermal LD50 (rabbit): >2000 mg/kg (estimate)

OTHER ACUTE EFFECTS

No Data

CHRONIC/SUBCHRONIC DATA

No delayed, subchronic or chronic test data are known.

SECTION 4 - FIRST AID

EYE CONTACT

Hold eyelids apart and immediately flush eyes with plenty of water for at least 15 minutes.
Call a physician.

SKIN CONTACT

Remove product and immediately flush affected area with water for at least 15 minutes. Remove contaminated clothing and shoes.
Wash before reuse. Call a physician.
Call a physician.

INHALATION

In case of inhalation or suspected inhalation, move the patient at once to fresh air and call a physician. Keep patient absolutely quiet and start oxygen inhalation through suitable equipment.

INGESTION

If swallowed, call a physician immediately. Remove stomach contents by gastric suction or induce vomiting only as directed by medical personnel. Never give anything by mouth to an unconscious person.

SECTION 5 - FIRE AND EXPLOSION DATA

CHARACTERISTICS:

FLASH POINT	171C (340F)
FLASH POINT METHOD(S)	Closed cup
UPPER EXPLOSION LIMIT (UEL)	No Data
LOWER EXPLOSION LIMIT (LEL)	No Data
AUTOIGNITION TEMPERATURE	No Data
FIRE HAZARD CLASSIFICATION (OSHA/NFPA)	Combustible Liquid, Class IIIB

EXTINGUISHING MEDIA

Ignition will give rise to a Class B fire.
In case of fire use: Water Spray, Carbon Dioxide (CO₂), Dry
Chemical, Alcohol Foam.

SPECIAL FIRE FIGHTING PROCEDURES

In case of fire and/or explosion do not breathe fumes (S41).
Use water spray to reduce vapors. If water pollution occurs,
notify appropriate authorities.
Wear NIOSH approved self-contained breathing apparatus with
independent air supply.
Keep containers cool with water spray. Avoid skin contact.

UNUSUAL FIRE AND EXPLOSION HAZARDS

May generate toxic or irritating combustion products.
Sudden reaction and fire may result if product is mixed with an
oxidizing agent.

SECTION 6 - REACTIVITY HAZARD DATA

CHEMICAL STABILITY

Stable

CONDITIONS TO AVOID (if unstable)

Not applicable

INCOMPATIBILITY (Materials to Avoid)

Oxidizing Agents (i.e. perchlorates, nitrates etc.)
Cleaning solutions, such as chromerge (sulfuric acid/dichromate)
and aqua regia.
A reaction accompanied by large heat release occurs when the
product is mixed with acids.

HAZARDOUS DECOMPOSITION PRODUCTS (from burning, heating, or reaction with other materials)

Carbon Monoxide in a fire. Carbon Dioxide in a fire. Nitrogen
Oxides in a fire. Nitrogen oxide can react with water vapors to
form corrosive nitric acid (TLV=2 ppm).
Combustion of product under oxygen-starved conditions can be
expected to produce numerous toxic products including: nitriles,
amides.
Irritating and toxic fumes at elevated temperatures.

HAZARDOUS POLYMERIZATION

Will not occur

CONDITIONS TO AVOID (if polymerization may occur)

Not applicable

SECTION 7 - SPILL, LEAK AND WASTE DISPOSAL INFORMATION

CONTAINMENT TECHNIQUES (Removal of ignition sources, diking etc)
Ventilate the space involved. Shut off or remove all ignition sources. Construct a dike to prevent spreading.

CLEAN-UP PROCEDURES

If recovery is not feasible, admix with dry soil, sand or non-reactive absorbent and place in a container or dumpster pending disposal.
Place in metal containers for recovery or disposal.
Remove from the spill location. Flush area with water spray.
Clean-up personnel must be equipped with self contained breathing apparatus and butyl rubber protective clothing.

OTHER EMERGENCY ADVICE

Avoid skin contact. Wear protective clothing.
Avoid contamination of ground and surface waters.
Potential for carbon monoxide and/or nitrous oxides generation in a fire must be recognized.

WASTE DISPOSAL

Dilute with organic solvent and incinerate using effluent gas scrubber.
Comply with all Federal, State and Local Regulations. Dispose of in a permitted waste management facility if incineration or landfill is not practicable.

ENVIRONMENTAL EFFECTS

No Data

SECTION 8 - PERSONAL PROTECTION/EXPOSURE CONTROLS

EYE PROTECTION

Splash-proof eye goggles.
In emergency situations, use eye goggles with a full face shield.

HAND PROTECTION

Wear suitable gloves (S37). Nitrile rubber gloves.
In emergency situations, wear impermeable gloves with cuffs to prevent spread of material to area above the wrists.

RESPIRATORY PROTECTION

Not required under normal conditions. For emergency situations use self-contained breathing apparatus with pressure demand mode.

PROTECTIVE CLOTHING

Wear suitable protective clothing (S36). Long sleeved clothing.

ENGINEERING CONTROLS

In case of insufficient ventilation, wear suitable respiratory equipment (S38).
Maintain air concentrations in work spaces in accord with

standards outlined in Sections 2 and 3.

WORK AND HYGIENIC PRACTICES

Wash at the end of each workshift and before eating, smoking or using the toilet.
Change work clothing daily before leaving the work place.
Promptly remove clothing that becomes contaminated.
Examine protective gloves before using. Discard if find evidence of holes or cracks.

SECTION 9 - STORAGE AND HANDLING

STORAGE

Keep away from oxidizers, heat or flames. Keep in cool, dry, ventilated storage and in closed containers.

HANDLING

Avoid contact with skin or eyes. Avoid breathing of vapors.
Handle in well ventilated work space.

OTHER PRECAUTIONS

Emergency showers and eye wash stations should be readily accessible.
Adhere to work practice rules established by government regulations (e.g. OSHA).

SECTION 10 - TYPICAL PHYSICAL AND CHEMICAL PROPERTIES

PHYSICAL FORM	Mobile liquid
COLOR	Amber
ODOR	Ammoniacal Irritating
pH	Alkaline
VAPOR PRESSURE (mm Hg)	<1 @ 25C (77F)
VAPOR DENSITY (Air = 1)	No Data
BOILING POINT	No Data
FREEZING/MELTING POINT	No Data
SOLUBILITY IN WATER	Slight
SPECIFIC GRAVITY (Water = 1)	0.97 @ 25C (77F)
EVAPORATION RATE (Butylacetate = 1)	No Data
VISCOSITY (CPS)	11000 @ 25C (77F)
MOLECULAR WEIGHT	Mixture

SECTION 11 - TRANSPORTATION INFORMATION

DOT SHIPPING NAME RESIN COMPOUND - NOT DOT REGULATED
DOT BULK SHIPPING NAME RESIN COMPOUND - NOT DOT REGULATED

IMO SHIPPING DATA Not regulated

ICAO/IATA SHIPPING DATA Not regulated

SECTION 12 - U.S. FEDERAL REGULATIONS

TOXIC SUBSTANCES CONTROL ACT (TSCA)-

All components are included in the EPA Toxic Substances Control Act (TSCA) Chemical Substance Inventory.

OSHA Hazard Communication Standard (29CFR1910.1200) hazard class(es)
Irritant

EPA SARA Title III Section 312 (40CFR370) hazard class
Immediate Health Hazard

EPA SARA Title III Section 313 (40CFR372) toxic chemicals above "de minimis" level are
None

SECTION 13 - STATE REGULATIONS

PROPOSITION 65 SUBSTANCE(S) listed by the state of California under the "Safe Drinking Water and Toxic Enforcement Act of 1986"
None

NEW JERSEY TRADE SECRET REGISTRY NUMBER(S)
None

SECTION 14 - INTERNATIONAL REGULATIONS

CANADA

DSL

Included on Inventory

WHMIS HAZARD CLASSIFICATION

Class D Division 2B

WHMIS TRADE SECRET REGISTRY NUMBER(S)

None

WHMIS HAZARDOUS INGREDIENTS

Included in Section 2

WHMIS SYMBOLS

Stylized T

EUROPEAN ECONOMIC COMMUNITY (EEC)

EINICS MASTER INVENTORY

Polymeric substance; monomers included on inventory

Air Products and Chemicals, Inc.
7201 Hamilton Boulevard
Allentown, PA 18195-1501
Telephone (215) 481-4911

AIR
PRODUCTS 

EEC SYMBOL

Irritant

EEC COUNCIL DIRECTIVES RELATING TO THE CLASSIFICATION,
PACKAGING AND LABELING OF DANGEROUS SUBSTANCES AND
PREPARATIONS RISK (R) AND SAFETY (S) PHRASES

Irritating to eyes and skin (R36/38). May cause
sensitization by skin contact (R43).

Avoid contact with skin and eyes (S24/25). In case of
contact with eyes, rinse immediately with plenty of water
and seek medical advice (S26). Wear suitable protective
clothing, gloves and eye/face protection (S36/37/39).



Appendix F

Analysis of the Failure of the Lining in Building A93

Nature of the Failure

On Monday morning, January 27, 1997 a resident of Building A93, Anacostia Naval Station reported no hot water pressure. The BOQ manager, Mr. Clemons, reported the complaint that morning and again on Tuesday, January 28 to the Public Works Office. Before that time, Mr. Clemons stated there had been no suggestion of trouble, but in a later conversation he did say that the washing machine on the first floor east side had been slow in filling for about a week.

By Thursday morning, January 30, many bathroom taps were partially or completely blocked. This was most noticeable at the far ends of the building; taps in 214 and 215 were blocked but water was flowing in rooms 210-213. Cold water in the janitor's closet adjacent to room 108 flowed red for about ten seconds when first turned on. The washing machine adjacent to room 107 continued to fill slowly. The south end of the building was more severely impacted than the north end, and hot water lines were more impacted than cold.

Background

A lining was installed on interior surfaces of the drinking water piping system in Building A93, Anacostia Naval Station, between July 23 and August 2, 1996. The work was a demonstration-validation program intended to show that, for pipes which may leach lead or other heavy metals into drinking water, an impervious lining is more cost-effective than replacement of the piping. The work was funded by the DoD Environmental Security Technology Demonstration Program and performed by Insitu Pipe Coating, Inc., 3205 Production Avenue, Oceanside, CA 92054. The coating was developed by Code 6123, Naval Research Laboratory, Washington, DC 20375.

Layout of Building A93

Building A93 is a Bachelor Officers Quarters which contains 23 sleeping rooms. A floor plan is shown in Figures 1a (first floor) and 1b (second floor) and a plumbing diagram is shown in Figure 2. The building contains 15 private and 4 semi-private bathrooms. The building also has a mechanical room, janitor's closet, wet bar, laundry, and men's and ladies' restrooms on the first floor, and a janitor's closet, laundry and kitchen on the second floor. Neither Figure 1 nor Figure 2 is to scale.

Water enters the building in the mechanical room on the first floor. The hot water heater is also located in this room. The cold water runs to a main in the first floor ceiling; this is a single pipe which runs to the north and south ends of the building, and laterals to each sleeping room run off the main. The hot water also runs to a main in the first floor ceiling; this main has a parallel recirculating line which forms a loop, allowing the water to be returned to the mechanical room for reheating. Laterals to each sleeping room run off the hot water main but not off the recirculating line; the latter is a single unbranched pipe running the length of the building.

Process of Installing the Lining

Installation of the lining was accomplished by isolating sections of pipe, drying the pipe with compressed air, grit blasting the interior to remove corrosion products and provide a clean rough surface, injecting a 100% nonvolatile paint into the pipe with compressed air to coat the surface, and finally passing a stream of warm dry air through the pipe while the coating cured. The water in the coated pipe system was tested and approved prior to the system being returned to service.

Pipes were lined without removal or extensive disassembly. Trailer-size air compressors were placed outside the building and air hoses led inside where they were connected to the piping system at each sink, shower and toilet outlet. A hose connected to the pipe at the water main inlet led outside to a dust collector. Hot dry air was blown through the pipe, and abrasive grit was added to remove rust or other contaminants and give the inside of the pipe a rough surface. Paint was then blown through the pipe and allowed to harden. The stream of hot air was maintained in order to cure the paint thoroughly. After the paint had cured water was flushed through the pipe and then allowed to stand undisturbed overnight; this process was repeated. The water was then tested to ensure that no undesired substances were present, and the piping system was returned to service.

Epoxy Lining

The lining used in the piping was a two-component epoxy--polyamide lining designated APL 2000¹ and manufactured by American Pipelining Corporation, 5780 Chesapeake Court, Suite #1, San Diego, CA 92123. Component 1 was the epoxy base, lot number 60196, and Component 2 was the hardener, lot number LC15B12446; the date of manufacture for both was

100 BLDG. 93 ANACOSTIA, NEH
 FIRST FLOOR P. 2
 MAX. CAPACITY T. 6
 TOTAL CAPACITY: T 8
 P. 11

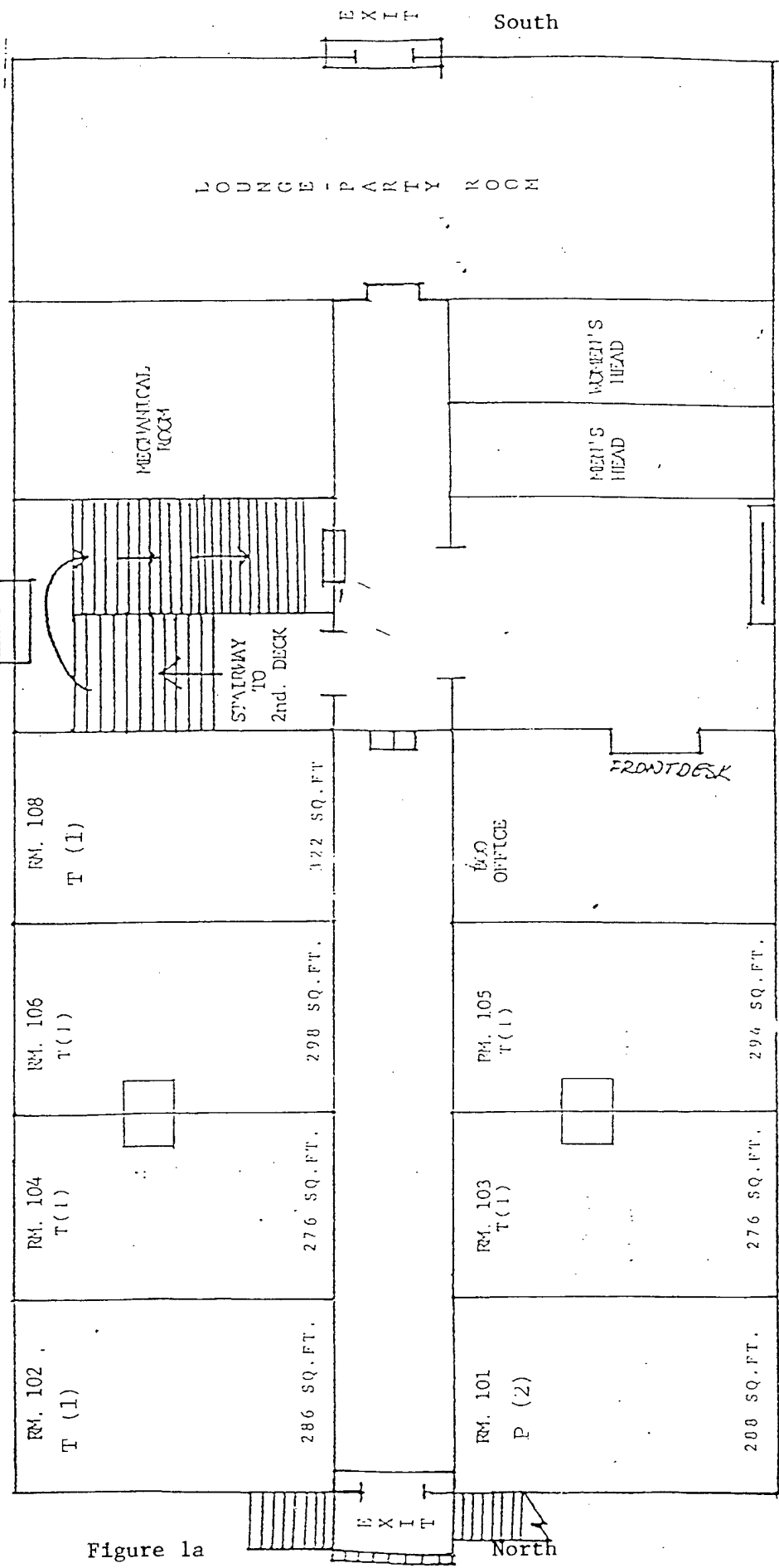

Figure 1a

ROCK'S SHARE BATH #104 W/105

2nd. DECK T. 8
 MAX. CAPACITY P. 9

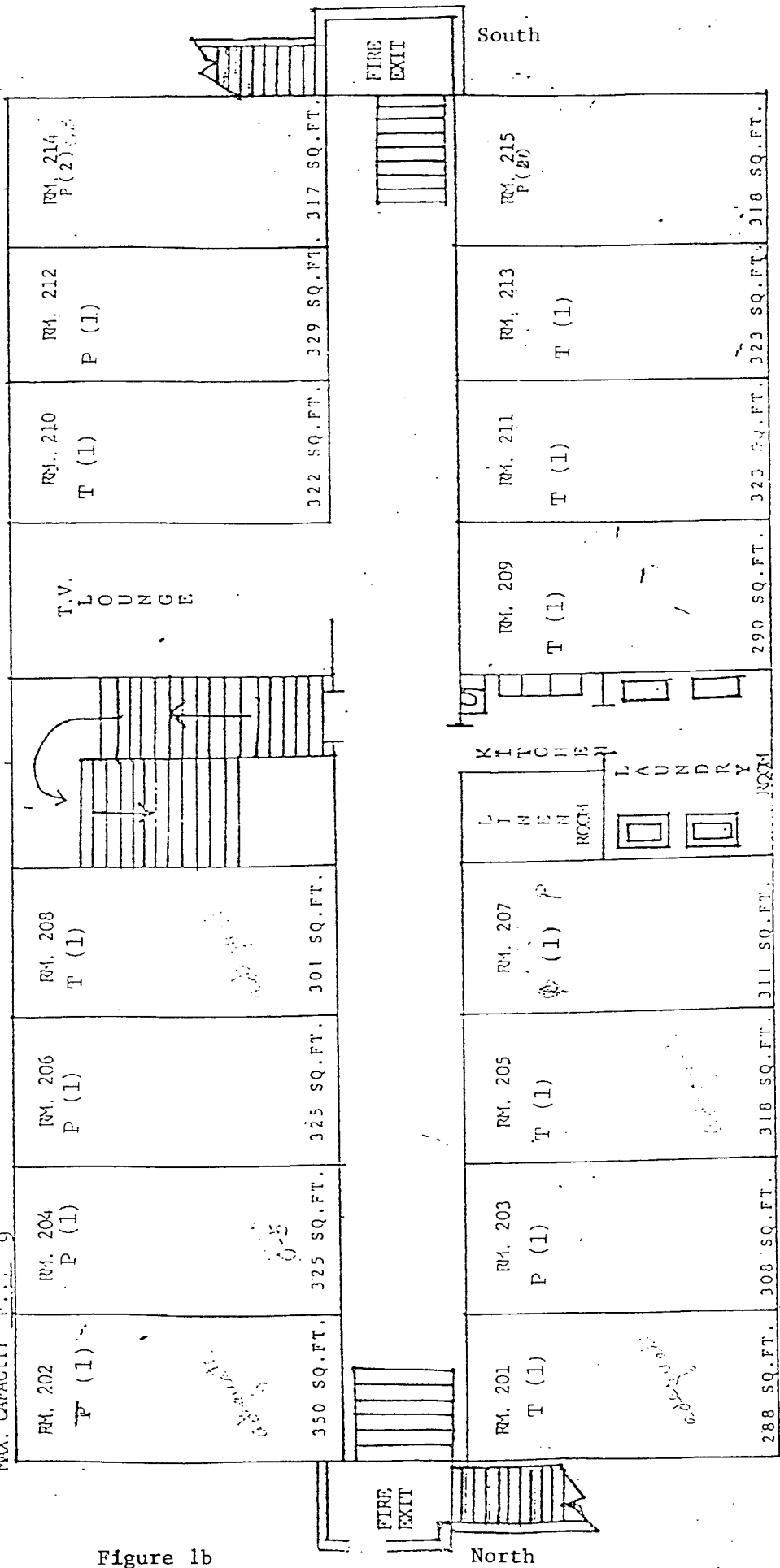

Figure 1b

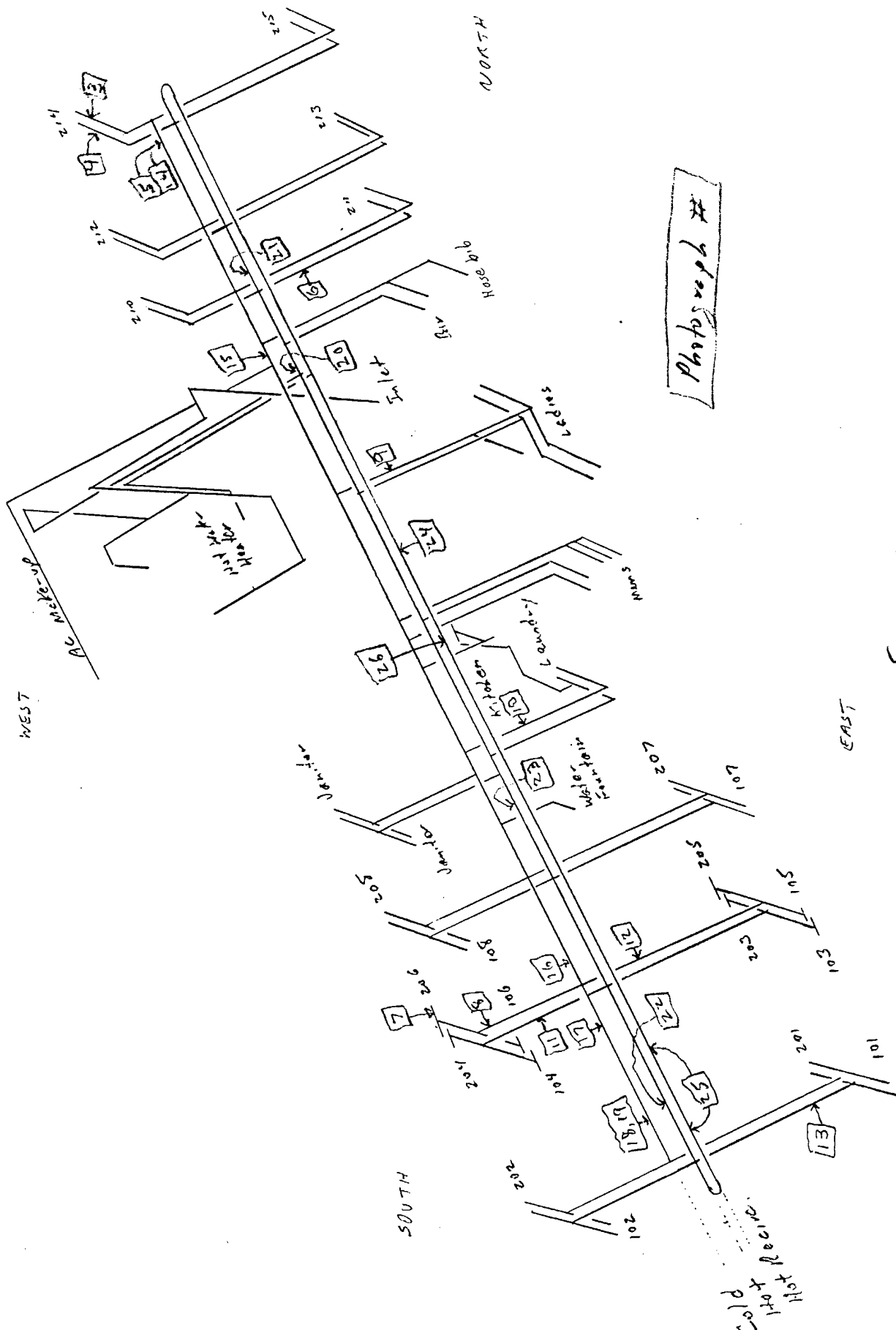

Figure 2

June 1996. The lining was tested and approved by NSF International of Ann Arbor, Michigan using procedures stipulated in ANSI/NSF Standard 61, "Drinking Water System Components - Health Effects."² NSF International is the sole firm authorized by the Environmental Protection Administration to test and approve materials for contact with drinking water. The lining was developed at the Naval Research Laboratory, Code 6123, and has been licensed to American Pipelining Corporation for installation in domestic hot and cold potable water systems.

Abrasive Grit

The abrasive used to clean the pipes was garnet, obtained from Emerald Creek Garnet, Fernwood ID 83830 and Barton Mines, Lake George, NY 12185. Both 35 mesh and 60 mesh sizes were used.

Failure Analysis

Pipes removed from Building A93 were examined and photographed. Replacement began at the north end and proceeded to the south end, and this report is organized in the same way. This Report begins with the lateral lines leading from the mains to the individual rooms, then describes the cold water main, hot water main, and hot water recirculating line, and ends with a discussion of the valves.

In the photographs used to document the condition of the piping, the lighting and camera angle were chosen to best capture the appearance of the lining and the pipe. Pipes usually needed to be rotated from their position in the building to accomplish this. Do not assume that the top of the pipe in a photograph is the same as the top of the pipe when it was installed in the building. In Figure 2, numbered boxes correspond to Figures 3 - 26 and show where piping was removed for photographs.

Pipes in the branches to the individual bathrooms

Workmanship in these lines was usually satisfactory. Linings showed good adhesion but were often rough, suggesting contamination with dust from the blast cleaning operation.

Some of the feed lines to bathroom taps were blocked with debris. Figure 3 shows the hot water line just behind the tap in room 214; this debris was packed hard and more than 3/4" deep.

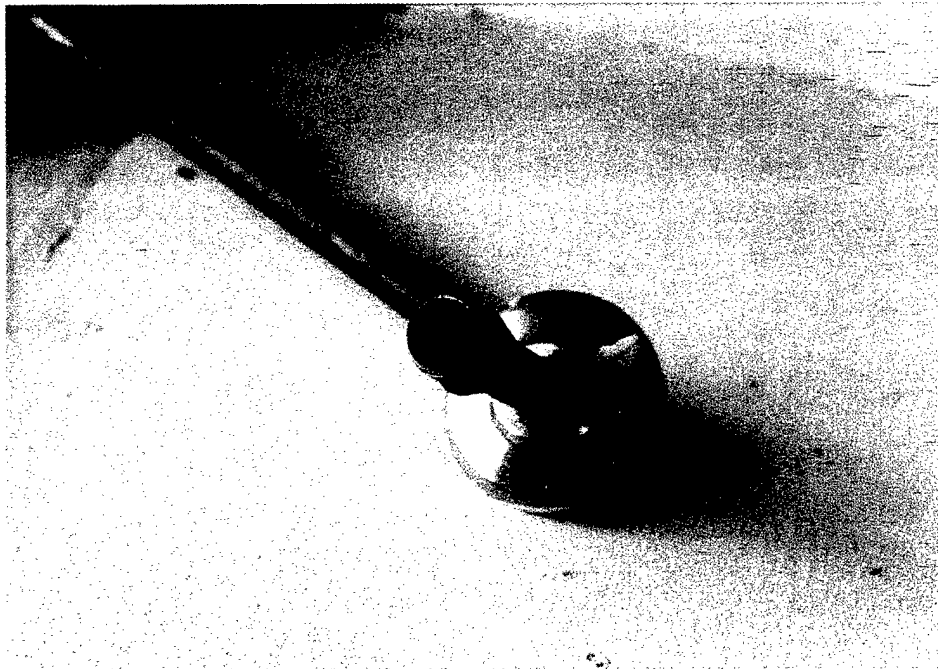

Figure
3

Paint in the cold water riser to room 214 was rippled, indicating that it sagged before drying; thickness is reasonable but the paint has entrained grit which makes it rough (Figure 4). Where this line became horizontal and entered the main, the coating was thicker on the bottom of the main (Figure 5).



Figure
4

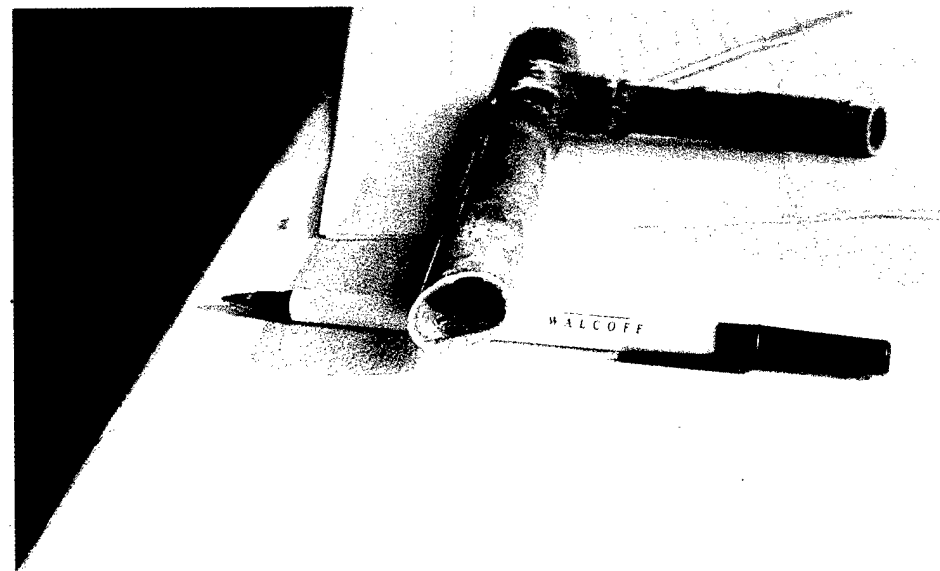

Figure
5

The cold water line to room 211 showed proper thickness and good adhesion, but contained much entrained grit (Figure 6). Some of the pipes, such as the cold water feed in room 210, contained excessively thick coating or no coating at all. In the cold water line to room 206, just behind the tap the coating is excessively thick and porous (Figure 7),



Figure 6

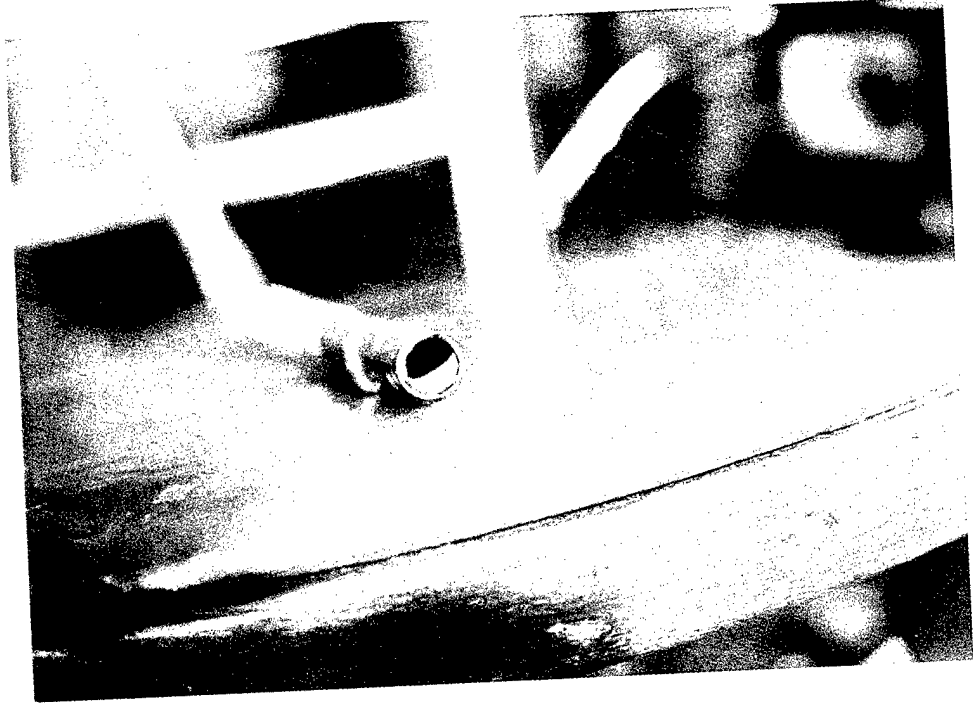

Figure 7

but 24 inches toward the main there is no coating at all (Figure 8). The cold water line (Figure 9) to the ladies room near the first-floor lobby and to room 207 was at the upper limit of thickness on the bottom and very rippled.

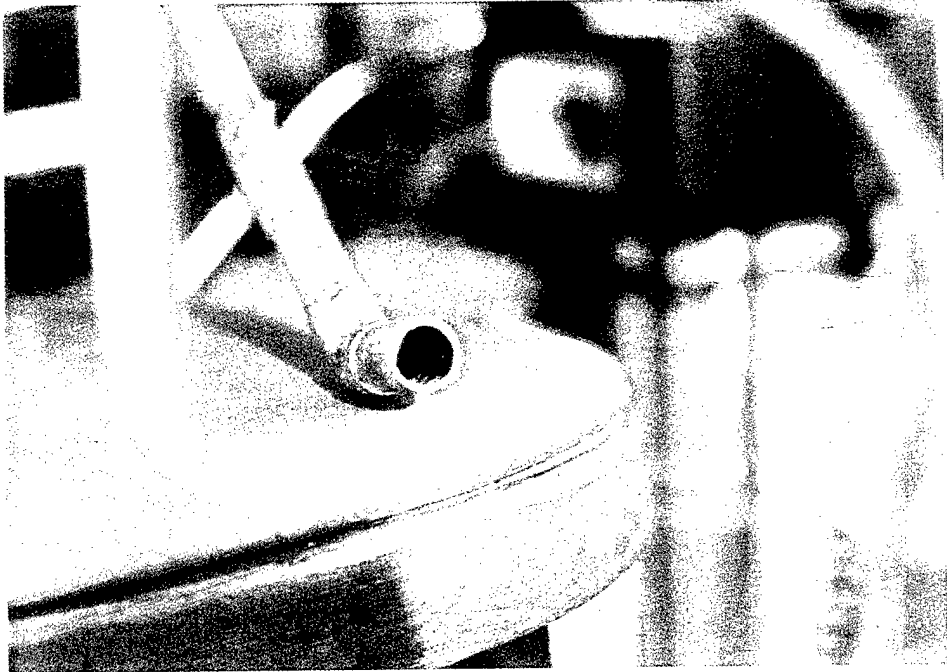

Figure 8

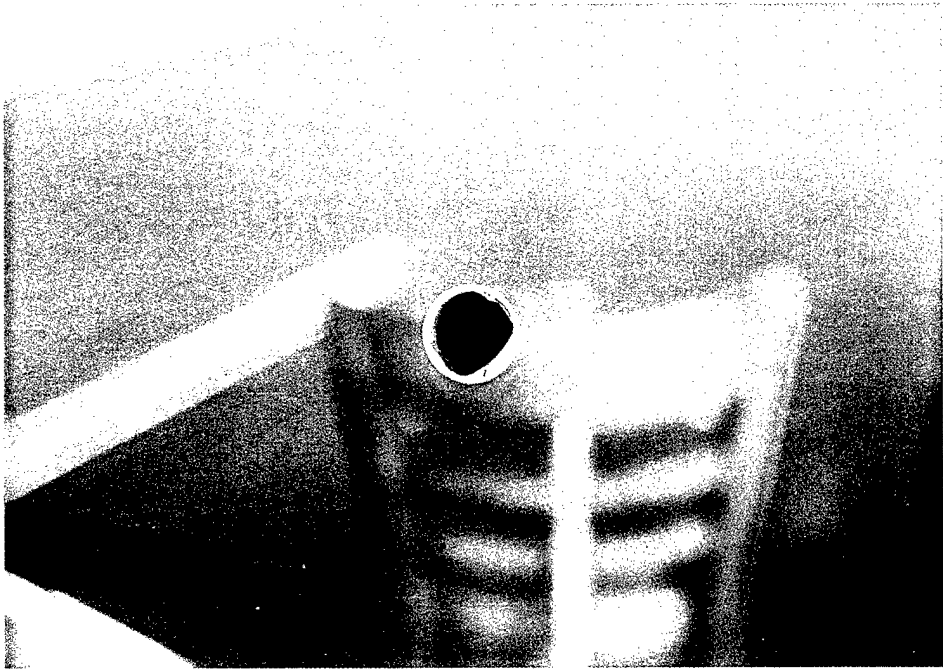

Figure 9

The hot water line leading to laundry on the first floor between room 107 and the booking office showed good adhesion, but the paint is excessively thick and severely rippled (Figure 10). The lining in the hot water pipe to room 106 (Figure 11) was at the maximum permissible thickness and showed ripples, good adhesion, and some evidence of grit in the paint.

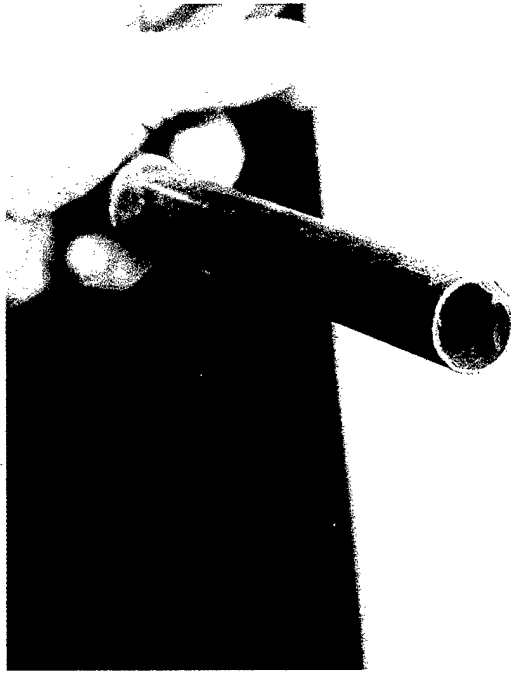

Figure
10

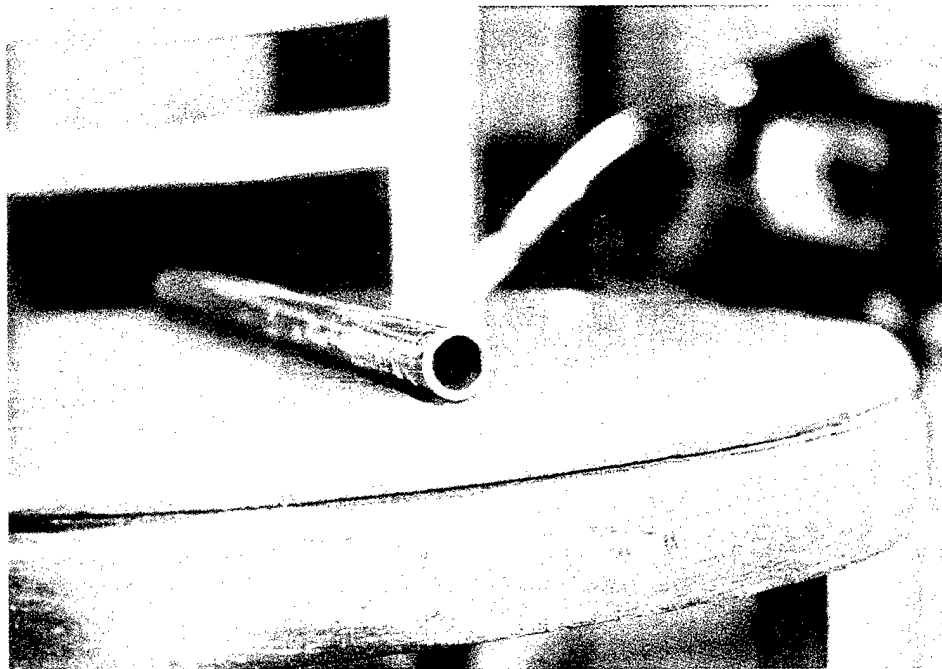

Figure
11

The lining in the cold water feed to room 105 (Figure 12) was excellent, showing proper thickness, good adhesion, and no contamination. Lining in the hot water line into room 101 was hard and smooth, adhered well, but was slightly thick on the bottom of the pipe nearest the tap (Figure 13).



Figure
12

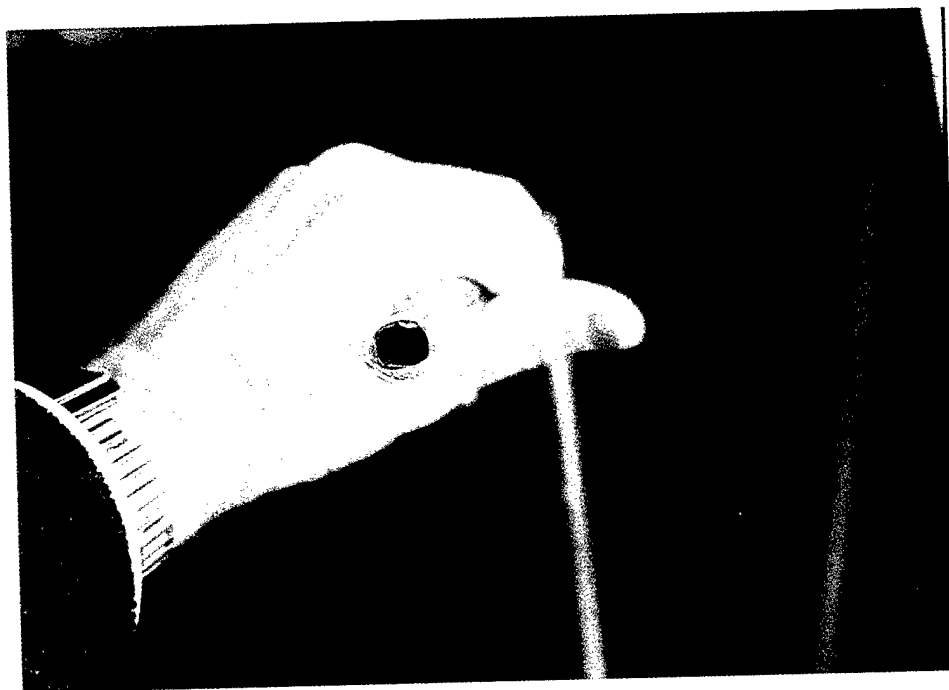

Figure
13

Cold water main

Workmanship in the cold water main is good at the north end but very poor at the south end. At the north end, the lining is generally smooth and glossy, with light rippling. Adhesion of the paint seems satisfactory. The paint is thicker on the bottom of the main at the north end of the building (Figure 14), but not so thick as to obstruct flow.

Figure 15 shows a valve and adjoining piping from the cold water main at the north end. The valve is operable but must pierce and crack paint in order to close. The coating is generally smooth, with light rippling but no blisters. Adhesion of paint seems satisfactory. Paint has a matte finish instead of the normal gloss.

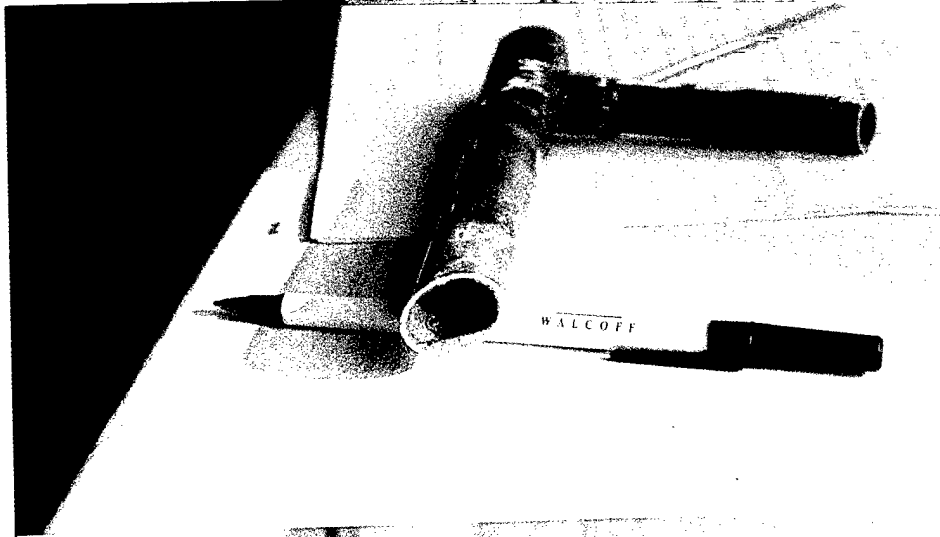

Figure
14



Figure
15

At the south end of the building, the paint is excessively thick and rippled (Figure 16). A valve in this line is painted open and cannot be operated (Figure 17).

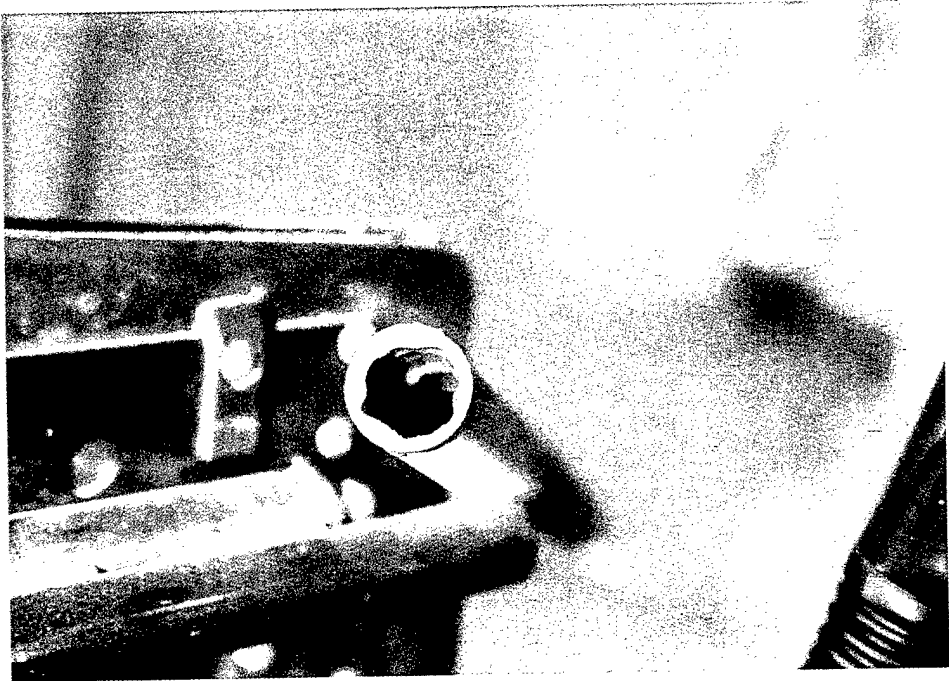

Figure 16



Figure 17

At the far south end of the building, the lining is excessively thick at one point, but stops abruptly leaving uncoated pipe. In a section of 1" cold water main from far south end of building, the paint is excessively thick at one end (Figure 18) but there is no paint at all at the other end (Figure 19). The roughness of the pipe surface at the uncoated end is very light on the bottom and sides, but there is no roughness at all on the top 60° of the pipe.

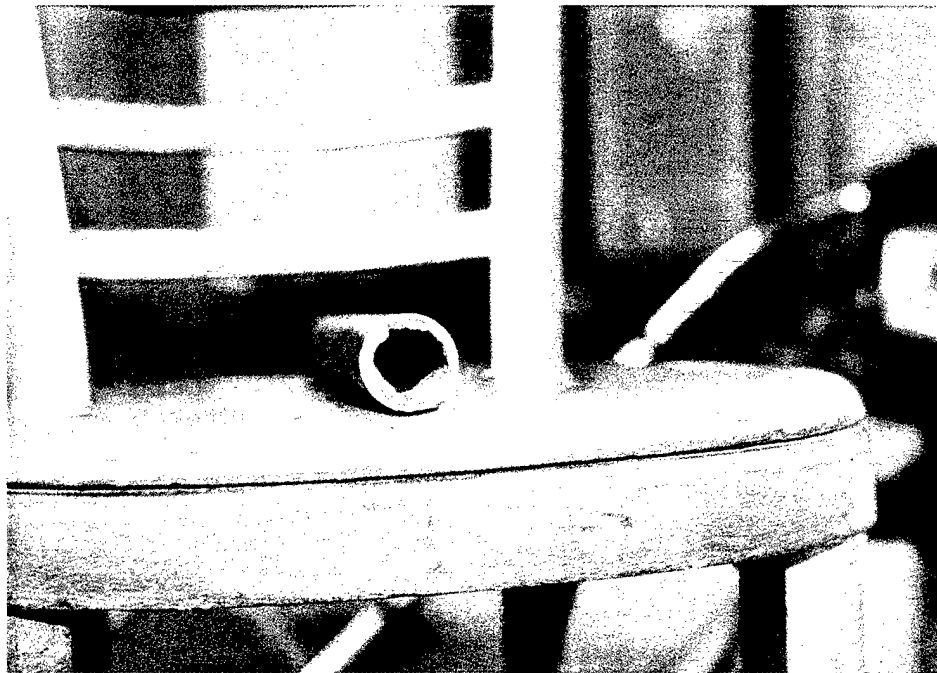

Figure
18

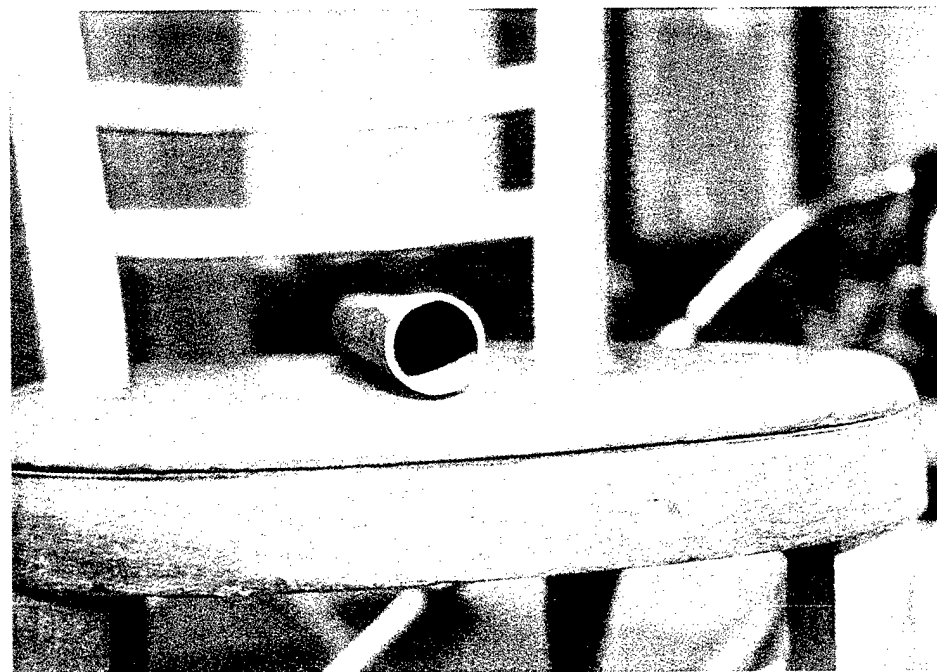

Figure
19

Hot water main

Figure 20 shows a section including a valve from the hot water main at the north end of the building. The thickness of paint in the pipe is acceptable, but the valve is painted open. A single blister about 8" long has formed at the top of the pipe. The interior metal surface of pipe is very smooth; there is no surface roughness at all.

Figure 21 shows the end of a 7-1/2-foot section of 1" hot water pipe from north end of building; the pipe is completely blocked. Paint had lost adhesion at top of pipe and been wrinkled and curled by water flow until it blocked the pipe.

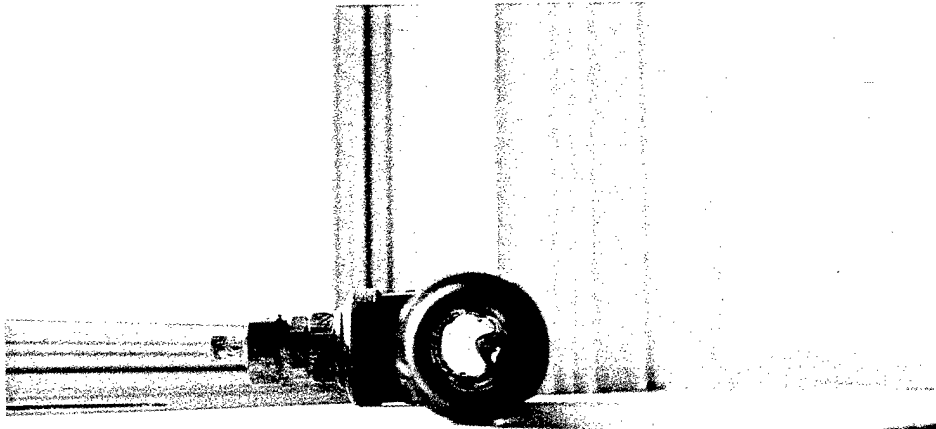

Figure
20



Figure
21

Figure 22 shows a section of pipe from the south end of the building. Adhesion to the bottom of the pipe is satisfactory, but paint on the sides and top of the pipe has lost adhesion to the metal and moved into the center of the pipe, where it may be broken loose by flowing water.

Figure 23 shows delamination of paint, leaving bare metal and flakes partially obstructing flow in hot water 2" pipe from ceiling in main hallway at south end of the building. The mottled black spots on the metal indicate that hot work has been done close to this site.

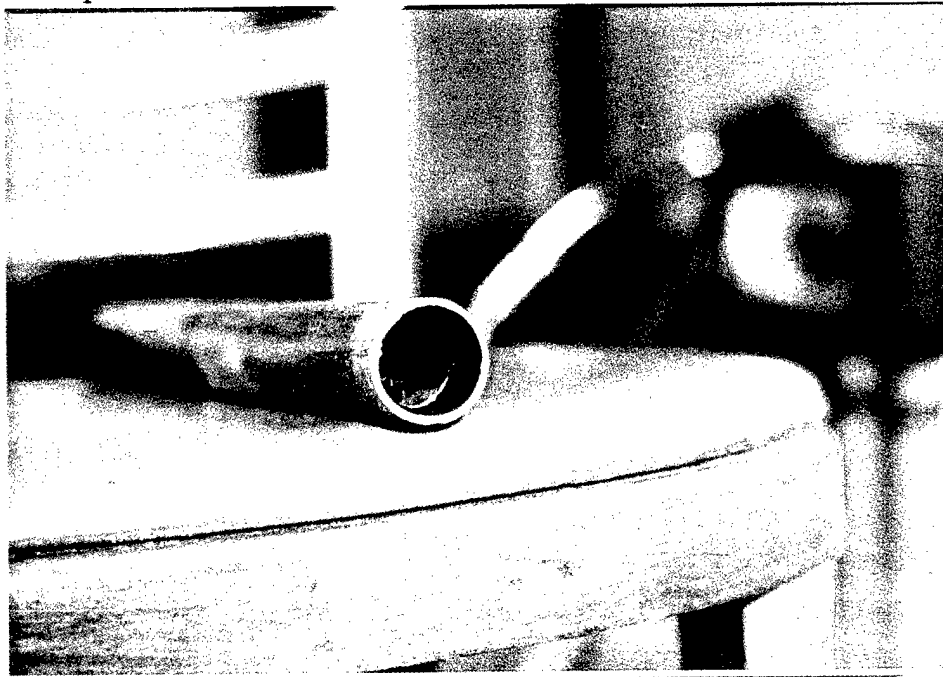

Figure
22

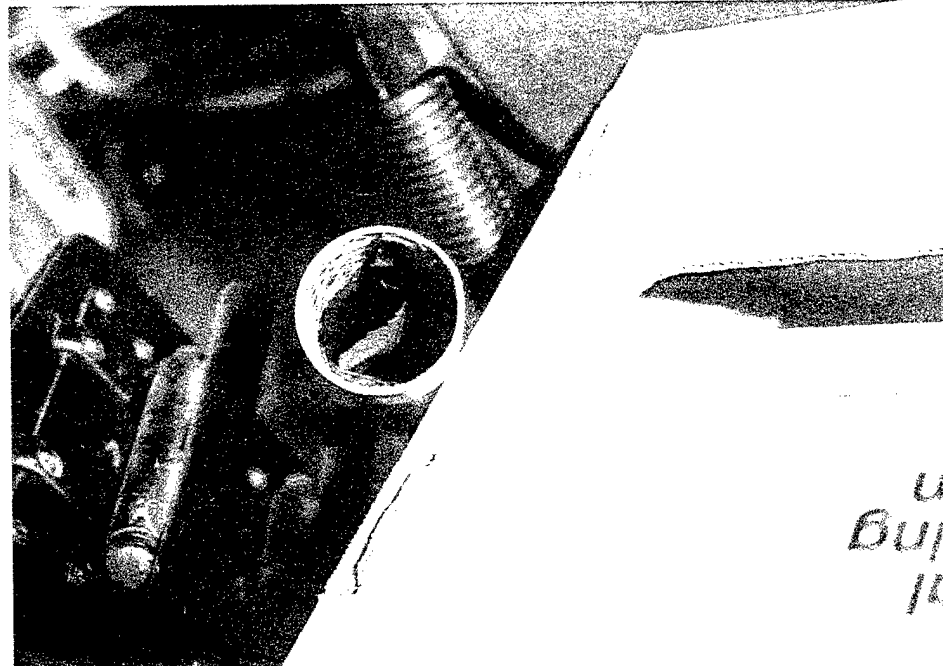

Figure
23

Hot water recirculating line

Figure 24 shows the 1 1/4" hot water recirculating line from the ceiling of the first floor center hallway. The paint is massively lumpy. Lumps are porous paint, they are not blisters, the pipe is not blocked. When the adhesion of the lining is tested with a knife, all adhesion is lost at the top of the pipe, but the bottom paint adheres well.

A 13-foot section of 3/4" hot water recirculating line from the far south end of the building was nearly obstructed by excessively thick paint. A pipe cutter was used to cut this pipe into 13 1-foot segments, and these are shown in Figure 25. The lining is not solid paint but is porous.

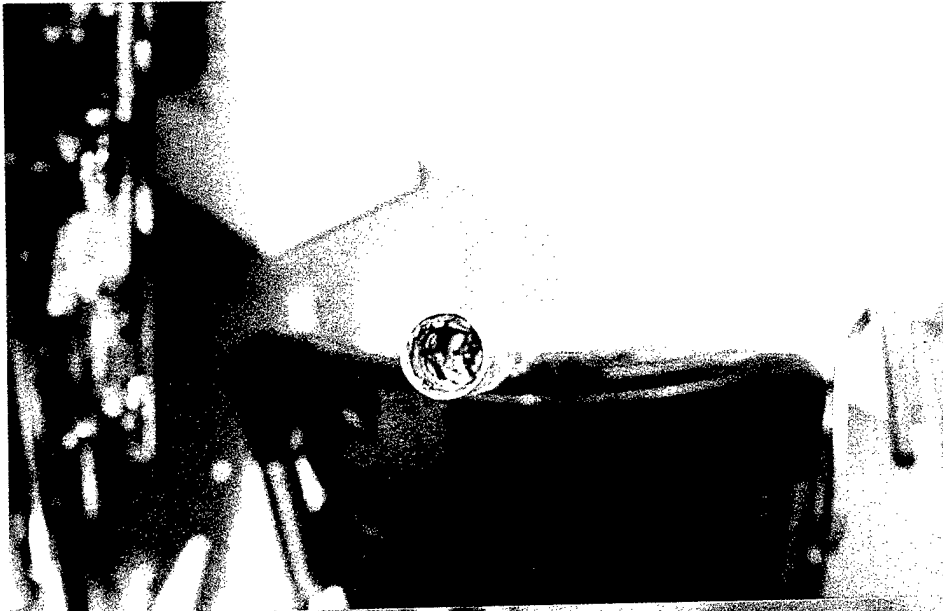

Figure
24

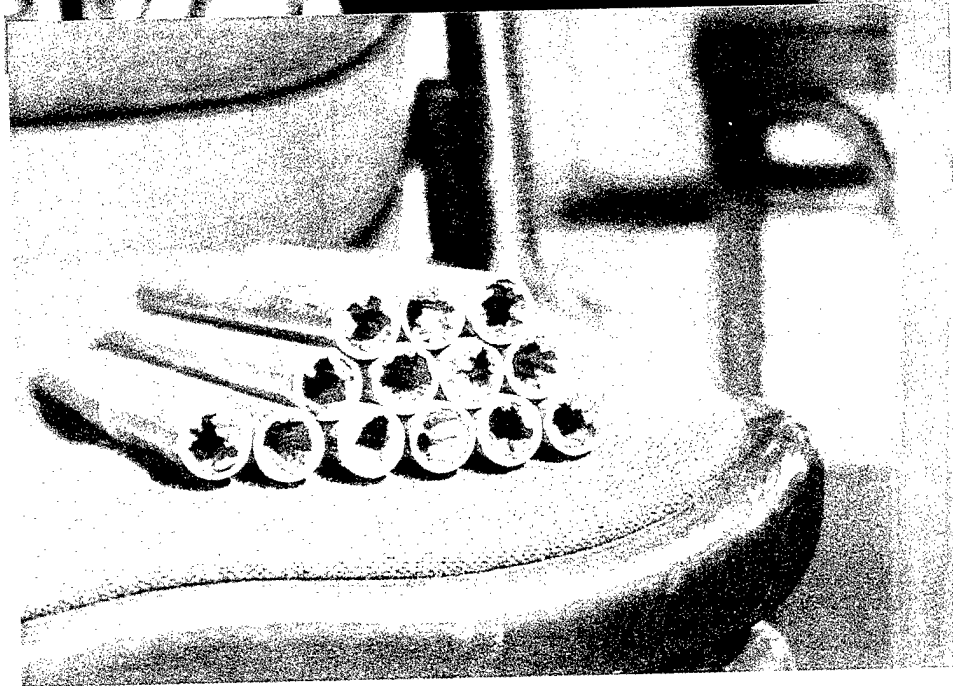

Figure
25

Valves

All valves were painted, and most were inoperable (see Figures 15, 17 and 20 above). The contract explicitly required valves to be removed from the lines before painting.

Figure 26 shows a valve from 3/4" hot water recirculating line which was not removed during painting. Paint covers the seat of the valve and prevents the valve from closing.

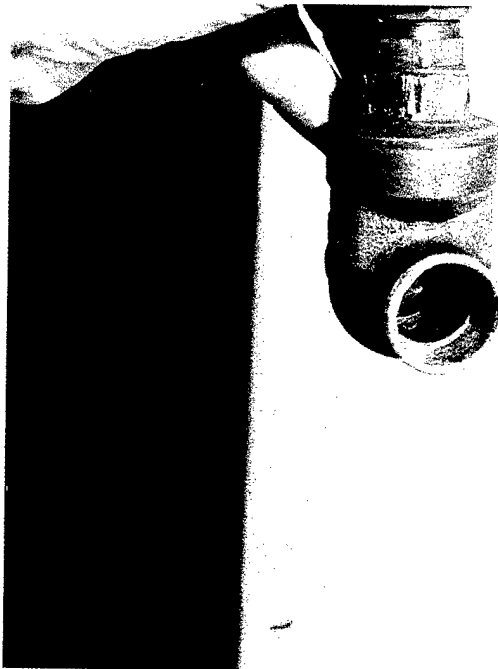

Figure
26

Other Relevant Information

Manufacture and mixing of the lining. Infrared spectra of paint flakes were used to determine if the paint was manufactured properly and mixed properly. Figure 27 shows spectra of lining from four places in the building. The position and intensity of the peaks shows that the paint was properly manufactured and mixed.

Use of lining by licensee. The lining used in this work is licensed to the American Pipelining Company, San Diego, CA, for installation in domestic hot and cold potable water systems. This firm was notified immediately and asked about any difficulty they might have encountered with the paint. After checking with their customers they stated they have no problems with the lining. In particular, a dormitory at the Portland Community College, OR was lined last summer and is operating without difficulty.

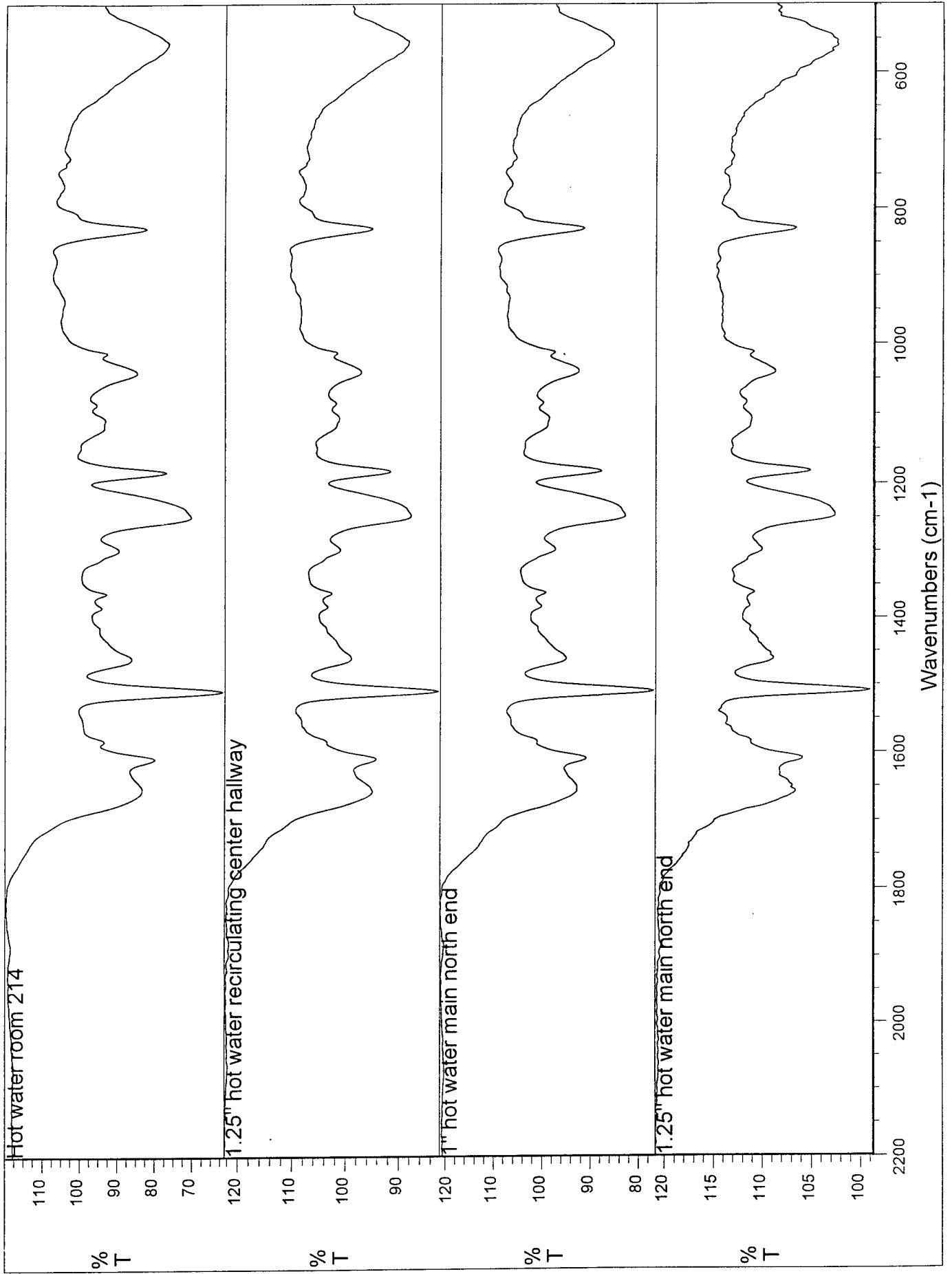

Figure 27

Chemical composition of lining. Tests were made to determine the amount of minerals in paint samples collected from different parts of the piping system. Paint samples were heated in air at 600 °C until they reached constant weight. The organic portion of the paint burned off, leaving the mineral content behind. Results of testing are shown in the following Table.

Ash content of paint samples

Description	Ash content, percent
Paint as manufactured	4.36
Room 214, hot water	11.82
Hot water recirculating line, center	13.92
Hot water main, north end	12.11
Hot water recirculating line, north end	6.36

Clearly the amount of ash obtained from paint taken from piping in Building A93 exceeds that from uncontaminated paint. This indicates that paint from Building A93 contains noncombustible foreign matter.

Porosity of the lining. This lining is intended to be applied as a smooth hard glossy film, and in much of the building this was in fact accomplished. However some paint, especially in the hot water recirculating line, is excessively thick, soft and porous. A photomicrograph (Figure 28) of paint from the hot water recirculating line in the south end of the building shows a fluffy open structure containing pores about 2 mils (0.002 inch) in diameter.

Contractor's process and schedule. Contractor production reports for each portion of pipe that was lined were required by the contract. In these reports the contractor states that he lined the building in three segments. Portions of those reports are reproduced *verbatim* below. [The contractor used "east" to designate the north end of the building, and "west" to designate the south end.]

Segment 1: Date: July 23, 1996 (Tuesday)

Location: East end of building first and second floors

Length: 310 feet

Remarks: A temporary hot and cold water system was constructed for all the rooms, kitchen and clothes washer. Treatment segment 1 was from the mechanical room east to the end of the building.

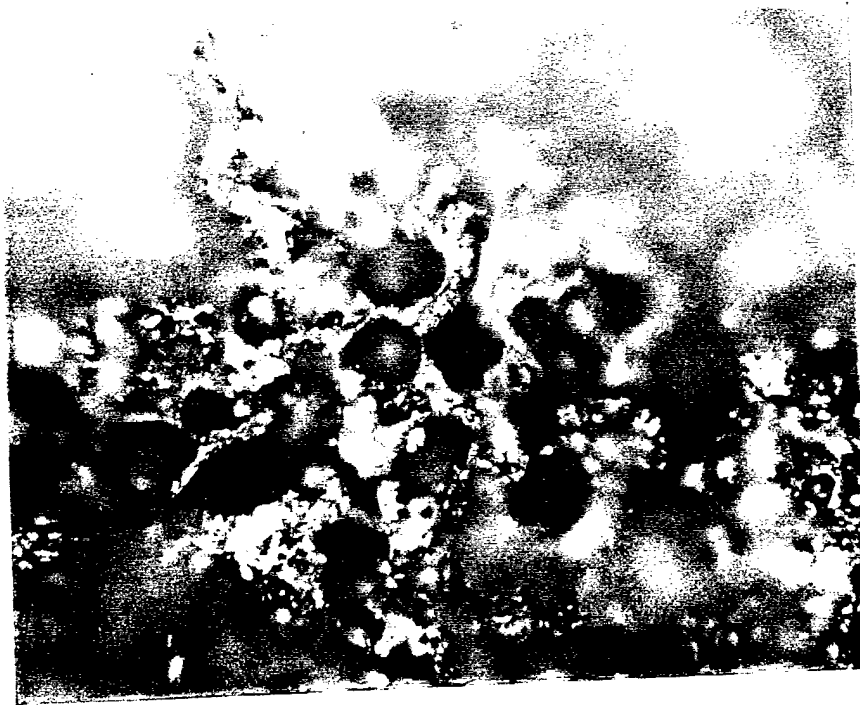

Figure
28

Segment 2: Date: July 26, 1996 (Friday)

Location: Mid-section first and second floor

Length: 729 feet

Remarks: Treatment segment 2 was from the mechanical room west half the distance to the end of the building. The recirculation pipe was not cut dividing the recirculation in three segments. The recirculation pipe was done in two segments.

Segment 3: Date: July 29, 1996 (Monday)

Location: West end of building first and second floor

Length: 486 feet

Remarks: Treatment segment 3 was from the end of segment 2 west to the end of the building. The second segment of the recirculation pipe was included in this treatment segment.

Temperature of hot water in BOQ. Statements of the BOQ manager, Mr. Clemons, the lead plumber, Mr. Watson, and my own observations agree that the hot water was maintained between 130 and 155 °F. The lining is approved for continuous use at 160 °F.

Differences in piping diameter and flow rates. Pipe at each shower, sink and toilet tap was ½" in diameter. The mains were 1 - 1¼" in diameter at the ends of the building but became up to 2" in diameter as they neared the mechanical room. The main where water enters the building in the mechanical room is 2½" in diameter.

Air velocity is inversely proportional to the square of the pipe diameter at a constant volume of air. Thus a stream of air at proper velocity in a ½" pipe will flow four times slower in a 1" pipe and nine times slower in a 1½" pipe.

The low degree of surface roughness in the larger pipe and the complete lack of surface roughness at the top of some of the larger pipe indicate that the air flow rate used by the contractor was too slow to prepare the surface of the larger pipes for painting.

Nature of disbonded paint. Loose debris in the water lines was in the form of soft, powder, not hard resin flakes. Powder is consistent with the material seen in the hot water recirculating line at the north end of the building. It is also possible that resin-rich flakes could be powdered by turbulence as they flow through the piping.

Findings

Figure 29 summarizes the observations of the lining in the piping in Building A93.

Specific findings are:

1. The lining was manufactured and mixed properly, and the lining was properly cured.
2. The ½-inch pipes leading to individual sleeping rooms were generally satisfactory, except for evidence of a small amount of entrained grit.
3. The piping was lined in three sections. Work in the north and mid-sections is adequate but contains minor defects such as variations in paint thickness, rippling of the paint surface, and a rough finish characteristic of grit entrapment. Large areas of the paint in the south end of the building are defective and are responsible for the blockage of the entire piping system.
4. During installation of the lining, air velocity through the mains was frequently insufficient to create the proper surface roughness for paint adhesion, especially at the top of the larger pipes. In many sections of larger pipe, there is no surface roughness at all on the top of the pipe. A rough surface is essential for painting copper and because it was not produced, paint detached from the top surface in some sections of pipe. Most significantly, however, air velocity was insufficient to remove dust from blast cleaning operations.

5. A critical error in this work was that dust from blasting was left in the hot water recirculating line at the south end of the building.
 - a) When paint was added, dust and paint combined to form a viscous paste which entrained air and formed an excessively-thick, poorly-adhering, porous crust. This was most severe in the hot water recirculating line at the south end of the building.
 - b) In some locations an excessively thick porous lining was adjacent to uncoated pipe, indicating that paint mixed with blasting dust was thick and resistant to flow.
 - c) In six months' time hot water penetrated, softened and removed particles of crust in the hot water recirculating line. These were carried in the water flow to frequently-used taps where they packed together and stopped the flow of water.
6. Valves were painted, contrary to an explicit statement in the contract that valves were to be removed before painting.
7. Paint in some sections of pipe was disbonded. Small black spots were evident on the side of the paint nearer the pipe, indicating that unauthorized hot work was performed on painted pipe.
8. The appearance and properties of the lining indicate that a number of other errors were made in cleaning the pipe and preparing the surface for painting. Although they did not contribute directly to the catastrophic failure of the paint, they are further indications of poor workmanship. Some of these defects are:
 - a) Sagging and rippling in the paint indicate that the pipe was not sufficiently heated before paint was applied, and/or the air was not hot enough during application of the paint.
 - b) Delamination and flaking of paint from the pipe indicates that the roughness of the pipe surface was insufficient to maintain adhesion.
 - c) Dust from blast cleaning is entrained in the paint, indicating that dust was not removed after cleaning.
 - d) Excessively thick crusts of paint indicate that large amounts of dust were mixed into the paint. The crusts did not possess the physical and chemical resistance of the uncontaminated paint.
 - e) A matte (instead of gloss) finish on some of the paint indicates that the air was not completely dry during application of the paint.
 - f) Excessively thick paint at the bottom of the pipe indicates that the volume, temperature, and/or the blowing time of the air was insufficient.
 - g) Lumpy paint indicates that air was blown too long or was too hot, or that paint was too close to its gel time when used.
 - h) Valves were not removed during lining but were painted, rendering them inoperable.

References to Appendix F

1. *NSF Listings: Drinking Water Additives - Health Effects*, May 7, 1996, published by NSF International, Ann Arbor, MI.
2. ANSI/NSF Standard 61, *Drinking Water System Components - Health Effects*, published by NSF International, 3475 Plymouth Road, PO Box 130140, Ann Arbor, MI 48113-0140, phone 313-769-8010, fax 313-769-0109.